



GLASS EXPANSION

Quality By Design

Innovations

for ICP-OES & ICP-MS

Glass Expansion is the world's leading supplier of sample introduction accessories and consumables for ICP-OES and ICP-MS.



Contents

Introduction	3	Torches.....	52
How is Glass Expansion Different?	3	Torch Designs.....	52
Technical Support.....	4	Torch Availability	53
Glass Expansion Warranty.....	8	D-Torch.....	54
GE Value Proposition – Highest Value for Money	9	RF Coils.....	60
Product Focus	10	Available RF Coils.....	61
Nebulizers	11	Cones.....	62
Nebulizer Selection	11	ConeGuard™ Thread Protector	63
Direct Connection (DC) Nebulizer	13	Magnifier Inspection Tool.....	64
SeaSpray Nebulizer.....	14	Accessories	65
Nebulizer Selection for Aqueous Solutions without HF ICP-OES.....	21	Maximizing Up-Time – Elegra Argon Humidifier	65
Nebulizer Selection for Aqueous Solutions without HF ICP-MS	22	Trident CT Kit.....	69
Nebulizer Selection for Solutions containing HF	23	Trident In-Line Reagent Addition Kit for HF Applications	70
Nebulizer Selection for Organic Solutions.....	24	Contour™ Flared-end Tubing	71
Nebulizer Maintenance	25	TruFlo Sample Uptake Monitor.....	74
Spray Chambers	27	Guardian In-Line Particle Filter.....	76
Spray Chamber Types	27	Guardian DC In-Line Non-Return Gas Filter	77
DC High Efficiency Spray Chamber	31	Guardian Autosampler Probe.....	78
HydraMist Simultaneous Cold Vapor/Pneumatic Nebulization Spray Chamber	32	Sample introduction kits for specific applications.....	79
Enhanced Single Cell Sample Introduction System for ICP-MS.....	35	Fittings & Connectors	80
IsoMist XR Programmable Temperature Spray Chamber	37	Summary.....	86
Peltier Cooled Cyclonic Spray Chamber for Agilent® ICP-MS.....	46	Webinars	86
IsoMist-MS.....	47	Product search function on GE website	87
Exclusive Helix CT interface between nebulizer and spray chamber.....	49	QR Code Information.....	88
Spray Chamber Selection Guide	51	Customer comments	89
		Glass Expansion Products	90

[How is Glass Expansion Different?](#) >

Technical Support >

Industry Standards >

Information >

Value Proposition >

Product Focus >

How is Glass Expansion Different?

Our products are designed by our experienced R+D team

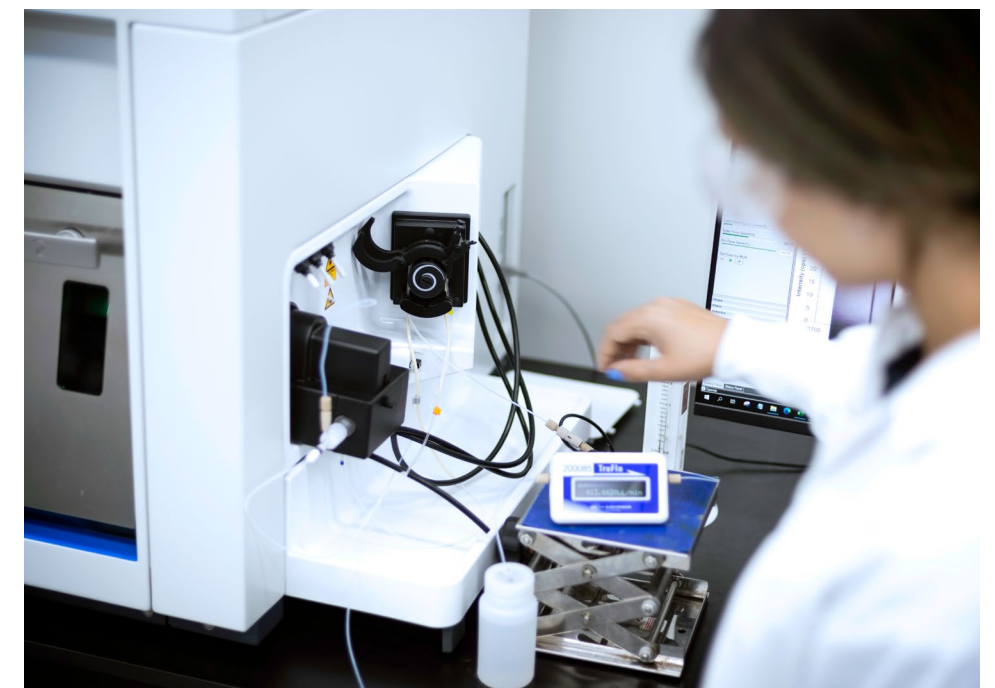
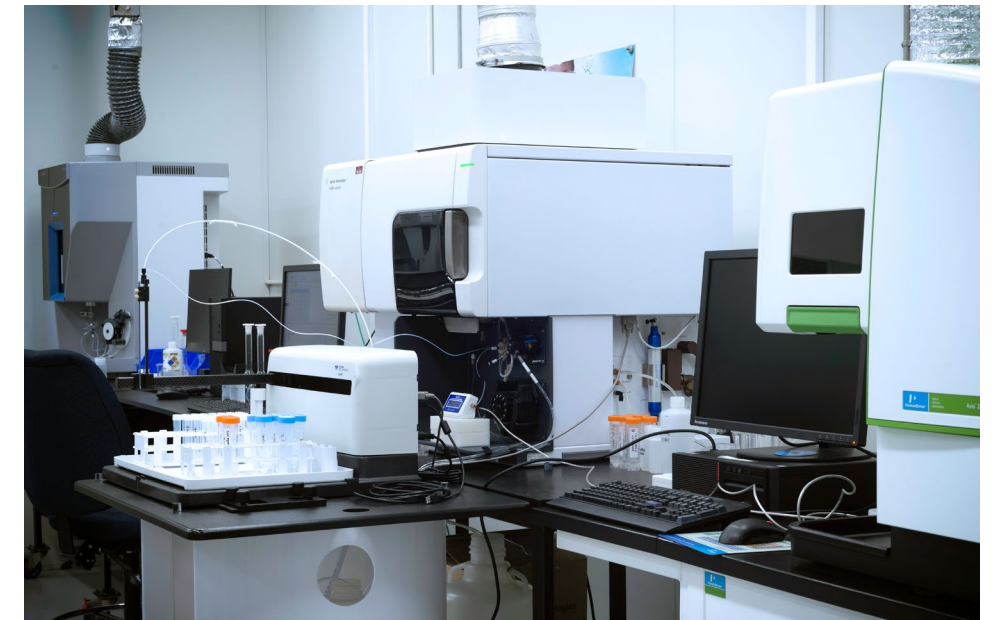
- Well thought out
- Meticulously designed
- Precisely manufactured

We provide our customers with full technical support

- Experienced applications scientists
- Extensively equipped laboratory with 5 in-house ICP spectrometers.

At our corporate headquarters in Melbourne, Australia, our test laboratory is equipped with PerkinElmer Avio® 200, Agilent® 5100 SVDV, and Thermo Fisher Scientific® PRO Duo ICP-OES instruments. In the case of ICP-MS, the laboratory is equipped with Agilent® 7900 and a Thermo Fisher Scientific® RQ.

This allows us to do real-world testing of new products so there is no doubt they will perform optimally in your instrument.



[Return to Contents Page](#)

[Back](#)

[Next](#)

[How is Glass Expansion Different?](#) >

[Technical Support](#) >

[Industry Standards](#) >

[Information](#) >

[Value Proposition](#) >

[Product Focus](#) >

Technical Support

All of the people shown have years of experience and a wealth of technical information to assist you to choose the best sample introduction system for your samples.

[Make an Enquiry](#) >



Jost Kaiser – CEO



Danny Brezni – COO



Ryan Brennan –
President, GE Inc.



Brian Boyd – Regional
Marketing Manager



Yoshi Yamano – Marketing
Manager - Asia/Pacific



Justin Masone –
Sales Manager, GE Inc.



Terrance Hettipathirana –
Applications Chemist/
ICP Specialist



Randy Mercurio –
ICP Technical Specialist,
GE Inc.



Jean Zhao – ICP Product
Specialist Asia/Pacific

[Return to Contents Page](#)

How is Glass Expansion Different? >

Technical Support >

[Industry Standards](#) >

Information >

Value Proposition >

Product Focus >

Many original GE designs are now industry standards

Many ICP users are not aware that the products that they routinely use with their ICP were designed by Glass Expansion. For more than 30 years, we have been developing products to make life easier for ICP users.

Our innovations include:

- Cyclonic spray chamber
- VitriCone nebulizer construction
- Helix CT Interface
- D-Torch
- IsoMist XR Programmable Temperature Spray Chamber
- TruFlo Sample Monitor
- Inline Guardian Particle Filter



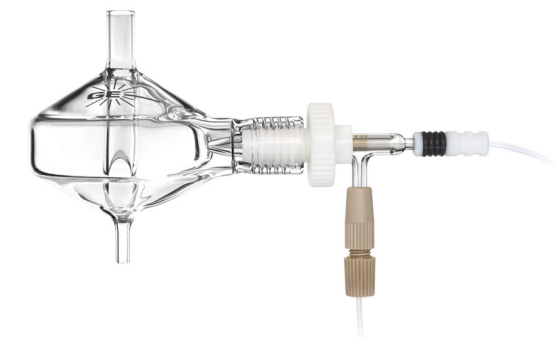
Cyclonic spray chamber

Before we introduced the cyclonic spray chamber, most ICPs used Scott-style spray chambers.



VitriCone nebulizer construction

We are still the only manufacturer making nebulizers using the solid VitriCone sample channel. All other companies use fragile drawn-glass capillaries.



Helix CT interface

Before we introduced the Helix CT, o-rings were used to seal the nebulizer in the spray chamber. Some companies still use this out-moded method today.

Introduction

[How is Glass Expansion Different?](#) >

[Technical Support](#) >

[Industry Standards](#) >

[Information](#) >

[Value Proposition](#) >

[Product Focus](#) >



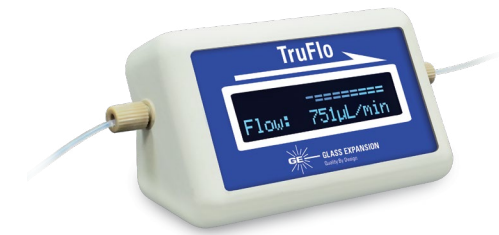
D-Torch

The D-Torch makes a demountable torch affordable and significantly reduces ongoing torch costs.



IsoMist XR

This is still the only system offering fully programmable control of spray chamber temperature.



TruFlo

This is the only product providing real-time measurement of the sample flow.



Inline Particle Filter

We are the only manufacturer making inline permanent filters at an economical price, which protects the sample introduction system from blockages.

Introduction

How is Glass Expansion Different? >

Technical Support >

Industry Standards >

Information >

Documents

Glass Expansion Warranty

Value Proposition >

Product Focus >

A wealth of information for the ICP user

Glass Expansion's experienced ICP experts have published a wealth of useful information for ICP users. Most users regard our catalog and website as essential references, but some may not be aware of the other material available. This material is available on request or through our website. And if the required information cannot be found in our published materials, our technical support team is happy to assist.

- Application notes
- Newsletters
- Catalogs
- Product flyers
- Website
- Product care advice
- Operating instructions
- Videos



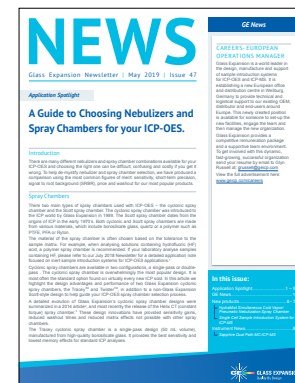
Flyers



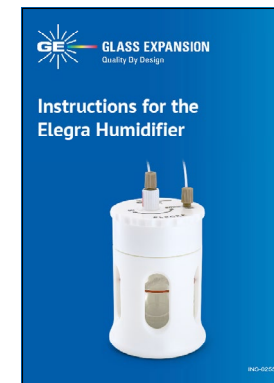
Catalogs



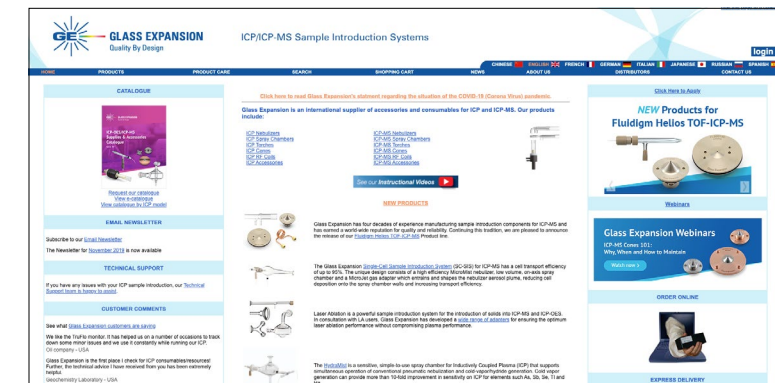
Application Notes



Newsletters



Instructions



Website

< Return to Contents Page

[How is Glass Expansion Different?](#) >

[Technical Support](#) >

[Industry Standards](#) >

[Information](#) >

Documents

[Glass Expansion Warranty](#)

[Value Proposition](#) >

[Product Focus](#) >

Glass Expansion Warranty

Customers sometimes ask if they can have a product on loan to evaluate its suitability for their application. With our Glass Expansion Warranty, this is not necessary. If a customer purchases one of our products and finds that it is not suitable for any reason, they can simply return the product for a refund or credit.

All Glass Expansion products are supplied with our guarantee. If the performance of the product is unsatisfactory or if it is unsuitable in any way, we will provide a credit or refund, provided it is returned in original condition within 14 days of receipt.

Glass Expansion Warranty

All Glass Expansion products are supplied with our Glass Expansion Warranty. If the performance of the product is unsatisfactory or if it is unsuitable in any way, we will provide a credit or refund, provided it is returned in original condition within 14 days of receipt*.



[More Information](#) >

[How is Glass Expansion Different?](#) >

[Technical Support](#) >

[Industry Standards](#) >

[Information](#) >

[Value Proposition](#) >

[Product Focus](#) >

GE Value Proposition – Highest Value for Money

Reproducibility – Never a need to re-optimize the parameters when a new component installed

- Saves time
- Essential for experiments

Long-life – High quality and innovative design reduce wear

- Saves money
- Reduces down-time

Dependability – over 30 years of experience

- Applications support saves time experimenting

GE Value Proposition – Nebulizer example

Let's examine our concentric glass nebulizers to determine the comparative value. There are two benefits to the design and reproducibility of our nebulizers:

- Because one nebulizer can be replaced by another of the same model with no re-optimization, one hour of labor is saved.
- Our unique and patented VitriCone capillary ensures consistent bore size throughout the entire length of the capillary. This results in a GE nebulizer lasting at least twice as long as a non-GE brand.

	GE Price	Brand X Price
Initial investment	Y	X
Time spent optimizing brand x nebulizer	Y	X+\$75
Half the lifetime for brand x nebulizer	Y	2(X+\$75)
Real nebulizer cost	Y	2(X+\$75)
e.g. \$500 GE vs \$400 X	\$500	\$950

In this example, the real cost of a Glass Expansion nebulizer is what you pay for it. However, there are hidden costs of a non-GE nebulizer, making it significantly more expensive even if the initial investment is lower.

The bottom line, when you buy a high-quality nebulizer such as one from Glass Expansion, you realize savings down the road, making it the best value.

[How is Glass Expansion Different?](#) >

[Technical Support](#) >

[Industry Standards](#) >

[Information](#) >

[Value Proposition](#) >

[Product Focus](#) >

Product Focus

- Nebulizers
- Cyclonic Spray Chambers
- DC High Efficiency Spray Chamber
- HydraMist Simultaneous Cold Vapor/Pneumatic Nebulization Spray Chamber
- Enhanced Single Cell Sample Introduction System for ICP-MS
- High-Efficiency Single Cell Nebulizer
- IsoMist XR Programmable Temperature Spray Chamber
- Peltier Cooled Cyclonic Spray Chambers for the Agilent Technologies® ICP-MS Models
- IsoMist-MS™
- D-Torches
- Elegra Argon Humidifier
- Trident CT™ In-Line Reagent Additions Kit
- RF Coils
- ICP-MS interface cones
- ConeGuard Thread Protector
- Contour Flared-end Tubing
- TruFlo sample uptake monitor
- Guardian In-Line Particle Filter
- Guardian In-Line Non-Return Gas Filter
- Guardian Autosampler Probe
- Application Kits
- Connectors
- Laser Ablation Adaptors

[Nebulizer Selection](#) ✓

[Selection](#)

Vitricone Capillary

DC Nebulizers >

Nebulizer Types >

Nebulizer Selection Guide >

Nebulizer Maintenance >

Nebulizer Selection

This is the range of nebulizers available. Each one has a variety of applications for which it is ideally suited. Only the VeeSpray model is not a concentric nebulizer design. It is instead a modified Babington type.

- Conikal – basic glass concentric
- SeaSpray – high-performance glass concentric
- MicroMist – low flow glass concentric
- Slurry – specialty glass concentric
- DuraMist – PEEK concentric
- OpalMist – PFA concentric
- Ceramic VeeSpray – ceramic non-concentric

[Nebulizer Selection](#)



Selection

[Vitricone Capillary](#)

DC Nebulizers



Nebulizer Types



Nebulizer Selection Guide



Nebulizer Maintenance

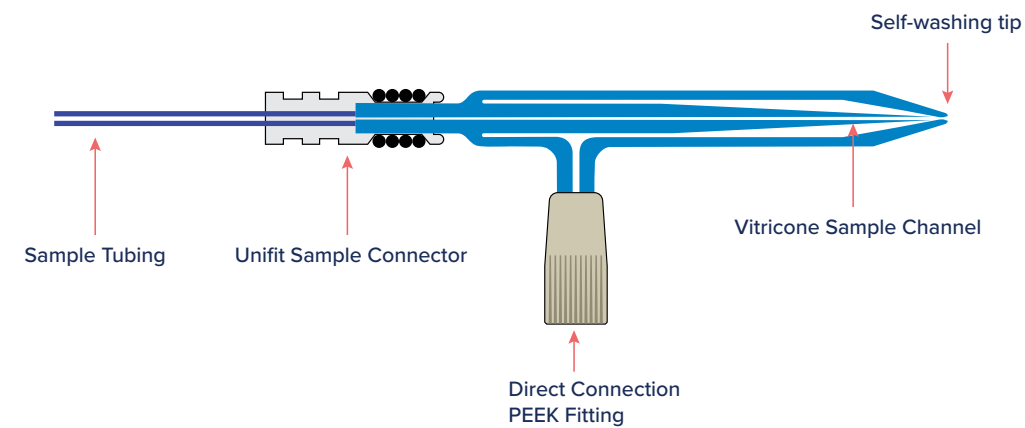


VitriCone capillary

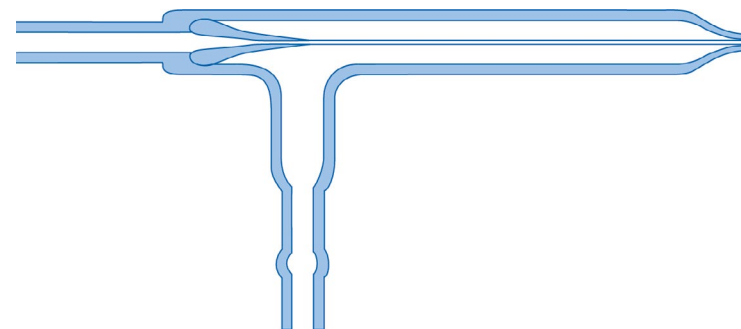
All Glass Expansion concentric glass nebulizers incorporate the unique VitriCone capillary. Other manufacturers heat and draw a thin fragile capillary from glass tubing to create the internal capillary. This process is prone to many problems including inconsistent inner diameter, an increase in the porosity of the glass, and harmonic vibrations from the flow of argon, all of which degrade performance and lifetime.

Glass Expansion is the only manufacturer that takes thick-walled constant-bore tubing and machines the outside to a uniform aerodynamic shape. This guarantees a uniform sample channel, assuring tolerance to nasty samples and perfect reproducibility. Also, note the zero dead volume UniFit sample line fitting, also unique to GE.

Glass Expansion SeaSpray nebulizer



Other brands



Nebulizer Selection >

[DC Nebulizers](#) >

Nebulizer Types >

Nebulizer Selection Guide >

Nebulizer Maintenance >

Direct Connection (DC) Nebulizer

The DC (Direct Connection) nebulizer has a UniFit sample connector which slides easily over the sample arm and an argon connector configured to connect directly to your ICP.

DC Nebulizer Benefits:

- Inert metal-free argon connector.
- Instrument-specific Direct Connect flexible argon line.
- Reliable ratchet fitting ensures leak-free gas connection.

In addition to these unique benefits, the DC nebulizer shares the following benefits with the U-Series nebulizer:

- **Resists blockage:** The sample channel is uniform from the entry point to the tip, so there is nowhere for particulates to be trapped.
- **Fast washout:** Since there is nowhere for the sample to be trapped, the fastest possible washout and highest sample throughput is achieved.
- **Simple to use:** Our proprietary UniFit connector slides easily over the sample arm and creates an excellent seal.
- Full-length VitriCone construction

DC versions of the SeaSpray, MicroMist, Conikal, Slurry, DuraMist, OpalMist, and VeeSpray nebulizers are available to suit the most common models of ICP-OES and ICP-MS.

The DC nebulizer part number has a prefix specific to each type of gas connector. For example, the prefix “A13-” denotes a connector for the Agilent® 5100/5110/5800/5900 ICP-OES, so part number A13-07-USS2 is a SeaSpray nebulizer configured for direct connection to the Agilent® 5100/5110/5800/5900.



P/N A13-07-USS2, SeaSpray DC Nebulizer Agilent® 5100/5110/5800/5900

Direct Connection (DC) Nebulizer

The Glass Expansion DC (Direct Connection) nebulizer has a UniFit sample connector which slides easily over the sample arm and an argon gas connector configured to connect directly to your ICP.

The benefits of the DC nebulizer are:

- Inert metal-free argon gas connector.
- Instrument-specific Direct Connect flexible argon gas line.
- Reliable ratchet fitting ensures leak-free argon gas connection.

The DC nebulizer shares the following benefits with the U-Series nebulizer:

Resists blockage
The sample channel is uniform from the entry point to the tip, so there is nowhere for particulates to be trapped.

Fast washout
Since there is nowhere for sample to be trapped, the fastest possible washout and highest sample throughput is achieved.

Simple to use
Our proprietary UniFit connector slides easily over the sample arm and creates an excellent seal.

Full length VitriCone™ construction
With the VitriCone™ design, the sample channel is constructed from heavy glass capillary which is machined to very high tolerances.

DC versions of the SeaSpray, MicroMist, Conikal, Slurry, DuraMist, OpalMist and VeeSpray nebulizers are available to suit the most common models of ICP-OES and ICP-MS.

The DC nebulizer part number has a prefix specific to each type of gas connector. For example, the prefix “A13-” denotes a connector for the Agilent® 5100/5110/5800/5900 ICP-OES, so part number A13-07-USS2 is a SeaSpray nebulizer configured for direct connection to the Agilent® 5100/5110/5800/5900.

<p>Head Office 1 Curtis Drive Foster City, CA 94024 415.353.1111 info@ge.com</p>	<p>Americas 17500 Central Expressway Unit 7, Fremont, CA 94538 415.353.1111 usa@ge.com</p>	<p>Europe P.O. Box 100 2000 Ghent Belgium +32 9 260 6100 europe@ge.com</p>
---	---	---

DC Nebulizer Flyer

< [Return to Contents Page](#)

Nebulizers

Introduction

Nebulizers

Spray Chambers

Torches

RF Coils

Cones

Accessories

Fittings & Connectors

Summary

Nebulizer Selection >

DC Nebulizers >

Nebulizer Types ✓

Seaspray

MicroMist

Conikal

Slurry

DuraMist

OpalMist

Ceramic VeeSpray

Nebulizer Selection Guide >

Nebulizer Maintenance >

SeaSpray Nebulizer

High Performance and Tolerance

The SeaSpray nebulizer is the best choice when samples contain high concentrations of dissolved solids. Seawater, brines, and plating baths are just a few examples of SeaSpray applications. However, it is not recommended when samples contain large particulates or HF. The SeaSpray nebulizer produces the finest aerosol particles resulting in sensitivity gains.

- Material: Borosilicate glass
- High physical reproducibility ~ 1%
- TDS tolerance, typically up to 20%
- Tolerance to particulates, typically up to 75µm
- Low RSD's due to highly accurate construction
- Standard available uptake: 2.0 and 0.4mL/min (1mL/min uptake available on request)

[More Information >](#)



The SeaSpray™ Nebulizer

The SeaSpray™ nebulizer has re-written the rules for analysis with ICP-OES and ICP-MS – providing improved precision and sensitivity as well as freedom from clogging while nebulizing up to 20% salt solutions.

The SeaSpray combines a unique self-washing to with the revolutionary Glass Expansion VitriCone construction. The SeaSpray nebulizer has been carefully designed with smooth surfaces to minimize adhesion of salt crystals. The design also uses the washing action of the dispersing orifices to further prevent crystal growth, allowing the SeaSpray to handle up to 20% salt solutions.

With some conventional glass nebulizer brands, the sample channel is constructed from fine drawn out capillary tubing. Glass Expansion nebulizers on the other hand, use the unique VitriCone construction. With the VitriCone design the sample channel is constructed from heavy glass capillary which is machined to very tight tolerances.

With the SeaSpray U-Series nebulizer, our proprietary UniFit connector slides easily over the sample arm and creates an excellent seal. As with all U-Series nebulizers, the sample channel is uniform from the entry point to the tip so there is nowhere for particulates to be trapped. And, since there is nowhere for sample to be trapped, you get the fastest possible washout and highest sample throughput. We supply SeaSpray U-Series nebulizers for all ICP-OES and ICP-MS spectrometers.

Benefits of VitriCone™ Construction

- The sample channel is uniform, so salt deposition is inhibited.
- The rugged precision-machined capillary resists vibration and delivers the best possible precision.
- The industry's tightest tolerances ensure that each nebulizer will perform to the same high standards as the

For more information visit: www.gelco.com/info/nebulizers

GLASS EXPANSION
Quality By Design

Asia Pacific	Americas	Europe
800-888-8888 1-800-888-8888 1-800-888-8888 www.gelco.com	800-888-8888 1-800-888-8888 1-800-888-8888 www.gelco.com	800-888-8888 1-800-888-8888 1-800-888-8888 www.gelco.com

SeaSpray Flyer

[Return to Contents Page](#)

Nebulizers

Nebulizer Selection >

DC Nebulizers >

Nebulizer Types ✓

Seaspray

MicroMist

Conikal

Slurry

DuraMist

OpalMist

Ceramic VeeSpray

Nebulizer Selection Guide >

Nebulizer Maintenance >

MicroMist Nebulizer

The low uptake nebulizer for all ICPs

When sample volume is limited, as may be the case for clinical or forensic samples, the MicroMist nebulizer is ideally suited. It is the nebulizer of choice for ICP-MS due to its smaller mean droplet size and efficient sample transport at low flow rates. However, for the ultimate in sample conservation plus matrix tolerance, we recommend the 0.4mL/min SeaSpray nebulizer.

- Material: Borosilicate glass
- High physical reproducibility ~ 1%
- TDS tolerance, typically up to 15%
- Low RSD's due to highly accurate construction
- Standard available uptake: 0.05, 0.1, 0.2, 0.4 & 0.6mL/min

[More Information >](#)



MicroMist DC Nebulizer
Industry Standard for ICP-MS Applications

The Glass Expansion MicroMist™ low-flow nebulizer is ideal for ICP-MS applications due to its excellent transport efficiency and precision. The MicroMist uses the same VitriCone™ technology as the industry standard Conikal and SeaSpray nebulizers, resulting in the most rugged and reliable high performance low-flow nebulizer available.

Glass Expansion MicroMist nebulizer

Benefits of the VitriCone Construction

- Sample channel is guaranteed uniform from entry point to nebulizer tip and thus resistant to clogging, in addition to providing a zero-dead volume sample connection.
- Rugged precision-machined capillary resists vibration and delivers the best possible precision.
- Industry's tightest tolerances ensure that each nebulizer will perform to the same high standards as the previous one.

Recommended Applications

- Applications requiring the highest sensitivity and precision, such as toxic metals in cannabis.
- ICP-MS applications where oxide interferences exist.
- Samples with limited volume, such as difficult to digest samples or biological.
- Radioactive samples that are expensive to dispose of.
- Volatile organic solvents that would otherwise cause an excessive load on the plasma.

GLASS EXPANSION
Quality by Design

Head office: 6 Conical Way, Purbeck, Dorset DT20 1JH, UK. Tel: +44 (0)1305 371111, info@glass.com

Americas: 31 Central Express Drive, Lind T, Purbeck, MA 01956 USA. Tel: +1 508 332 1111, americas@glass.com

Europe: 31 Central Express Drive, Lind T, Purbeck, MA 01956 Germany. Tel: +49 471 3776177, europe@glass.com

MicroMist Flyer

Glass Expansion MicroMist™
High Efficiency Nebulizer

The novel design of the high efficiency nebulizer used in the Glass Expansion single cell sample introduction system uses a low argon gas flow to provide high nebulization efficiency without rupturing the cell walls.

Glass Expansion's single cell nebulizer with proprietary VitriCone sample channel features:

- Superior transport efficiency at the sample uptake rates (15 to 45 uL/min) to ensure individual intact cells are transported into the plasma for measurement.
- Constant diameter, large bore sample channel minimizes blockages from sample build-up commonly experienced with biological samples.
- Rigid, precision machined thick-walled glass sample capillary gives the best analytical precision by resisting harmonic vibrations from the high linear velocity of the surrounding argon gas flow.
- Inert, metal-free DC gas fittings with matched mechanism give reliable, reproducible leak-free air connections.
- Easy to use, gas tight, zero dead volume sample fitting make connecting to the sample delivery system easy and reliable.

Part Number **Product Description**

C211-LP-T20	MicroMist Nebulizer 0.2mL/min uptake. Used for single cell analysis of biological materials.
F1-16-S-X	Zero dead volume high precision nebulizer fittings kit.
70-805-1070	DC Gas Fitting Type 21
70-81100	Nebulizer cleaning tool

GLASS EXPANSION
Quality by Design

Asia Pacific: 6 Conical Way, Purbeck, Dorset DT20 1JH, UK. Tel: +44 (0)1305 371111, asia@glass.com

Americas: 31 Central Express Drive, Lind T, Purbeck, MA 01956 USA. Tel: +1 508 332 1111, americas@glass.com

Europe: 31 Central Express Drive, Lind T, Purbeck, MA 01956 Germany. Tel: +49 471 3776177, europe@glass.com

MicroMist High Efficiency Nebulizer for TOF-ICP-MS Flyer

[Return to Contents Page](#)

Nebulizer Selection >

DC Nebulizers >

Nebulizer Types ✓

Seaspray

MicroMist

Conikal

Slurry

DuraMist

OpalMist

Ceramic VeeSpray

Nebulizer Selection Guide >

Nebulizer Maintenance >

Conikal Nebulizer

The Industry Standard for ICP-MS

The Conikal nebulizer is a general use nebulizer and is ideal for samples containing only moderate concentrations of dissolved salts, no particulates, and no hydrofluoric acid. A number of instrument manufacturers employ this nebulizer as part of their standard instrument configuration.

- Material: Borosilicate glass
- High physical reproducibility ~ 1%
- TDS tolerance, typically up to 5%
- Tolerance to particulates, typically up to 75µm
- Low RSD's due to highly accurate construction
- Standard available uptake: 1 & 2mL/min

[More Information >](#)



Nebulizer Selection >

DC Nebulizers >

Nebulizer Types ✓

Seaspray

MicroMist

Conikal

Slurry

DuraMist

OpalMist

Ceramic VeeSpray

Nebulizer Selection Guide >

Nebulizer Maintenance >

Slurry Nebulizer

Ideal for Wear Metals in Engine Oils

The Slurry nebulizer excels at exactly what it sounds like, the analysis of slurries. One common slurry application is the analysis of used engine oils for wear metals, and the Slurry nebulizer is the ideal choice. Any sample which consists of small particulates in a liquid matrix is a slurry and is suited to this nebulizer. It is important to note, however, that samples that contain high dissolved solids are not suitable for the Slurry nebulizer.

- Material: Borosilicate glass
- High physical reproducibility ~ 1%
- TDS tolerance, typically ~ 1%
- High tolerance to particulates, typically up to 150µm
- Low RSD's due to highly accurate construction
- Slurry nebulizers have a natural liquid uptake of 4mL/min but operate best between 1.5 and 2.5mL/min

[More Information >](#)



Nebulizers

Nebulizer Selection >

DC Nebulizers >

Nebulizer Types ✓

Seaspray

MicroMist

Conikal

Slurry

DuraMist

OpalMist

Ceramic VeeSpray

Nebulizer Selection Guide >

Nebulizer Maintenance >

DuraMist Nebulizer

Routine High Precision for HF Samples and High Salt Samples

The DuraMist concentric nebulizer is the most economical nebulizer for high precision analyses involving samples digested in HF. The DuraMist nebulizer is recommended for samples containing up to 5% HF.

- Material: HF Resistant PEEK
- High physical reproducibility ~ 2%
- Tolerance to particulates, up to 75µm depending on uptake
- TDS tolerance, typically up to 30%
- Low RSD's due to concentric geometry
- Uses only standard ICP argon supply pressures
- Standard 6mm size fits standard cyclonic spray chambers. Adaptors are available for Scott type spray chambers
- Standard available uptakes: 0.4 and 1.0 mL/min

[More Information >](#)



DuraMist™ High Performance Inert Nebulizer



Inert material
Made from PEEK and it can tolerate a wide variety of acids including HF.

High sensitivity and excellent precision
Due to concentric design and rigid construction.

High tolerance to dissolved solids
(Typically up to 30%) due to smooth surface of capillary and nebulizer tip.

High physical reproducibility
Inert material nebulizer to nebulizer variability so that changing nebulizers does not change your analytical performance.

The DuraMist™ is a HF-resistant nebulizer, providing excellent sensitivity and precision at an affordable price. The DuraMist is a concentric, self-aspirating nebulizer and is compatible with all ICP models. And its ability to run samples with up to 30% total dissolved solids without blockage make it effectively a universal nebulizer.

The strength and rigidity of the PEEK material allows the DuraMist to be manufactured to very tight tolerances, enabling it to closely match the Seaspray, the worldwide market-leading high performance glass nebulizer. A comparison of the DuraMist with the Seaspray showed that the DuraMist gives similar performance.

For more information visit: www.gemco.com/peek/cobalt200 or contact us at spquires@gemco.com

	Intensity	RSD
Seaspray	100	0.23%
DuraMist	87	0.23%

* The DuraMist nebulizer is recommended for samples containing up to 5% HF. For samples with higher concentrations of HF, we recommend the Qualifier PFA nebulizer.

For more information visit: www.gemco.com/peek/cobalt200 or contact us at spquires@gemco.com

GLASS EXPANSION
Quality By Design

Asia Pacific	Americas	Europe
11 Connaught Road, Singapore 408761	11 Southpoint Business Plaza, Suite 1000, 100 Southpoint Drive, Atlanta, GA 30329	Postfach 101556, 60505 Frankfurt am Main, Germany
853 3338 100, spquires@gemco.com	908 533 3600, peek@gemco.com	069 456 07000, spquires@gemco.com

DuraMist Flyer

[Return to Contents Page](#)

Nebulizers

Introduction

Nebulizers

Spray Chambers

Torches

RF Coils

Cones

Accessories

Fittings & Connectors

Summary

Nebulizer Selection >

DC Nebulizers >

Nebulizer Types ✓

Seaspray

MicroMist

Conikal

Slurry

DuraMist

OpalMist

Ceramic VeeSpray

Nebulizer Selection Guide >

Nebulizer Maintenance >

OpalMist Nebulizer

Ideal for ICP-MS work

The OpalMist has two primary applications as follows:

- For ICP-OES, it is the nebulizer of choice when samples contain both high dissolved solids and HF, but do not contain large particulates.
- For ICP-MS, the high purity of PFA makes it the preferred nebulizer for ultra-trace analyses.
- Material: PFA
- High physical reproducibility ~ 3%
- Strong and consistent self-aspiration
- Tolerance to particulates, up to 75µm depending on uptake
- TDS tolerance, typically up to 15%
- Low RSD's due to concentric geometry
- Standard 6mm size fits standard cyclonic spray chambers. Adaptors are available for Scott type spray chambers
- Standard available uptakes: 0.05, 0.1, 0.2, 0.4, 0.6 & 2mL/min

[More Information >](#)



OpalMist™ PFA Nebulizer

The OpalMist™ PFA concentric nebulizer is the nebulizer of choice for high precision analyses requiring the highest chemical resistancy to HF, alkalis and organics. The high purity PFA construction makes it ideal for ultra-trace ICP-MS work.

Ultra-Trace Analysis

When carrying out ultra-trace analysis, especially by ICP-MS, the risk of contamination must be minimized. The high purity of the PFA material used to make the OpalMist nebulizer provides the exceptionally low background necessary for ultra-trace determinations.

Highly Corrosive Samples

The totally inert construction of the OpalMist PFA nebulizer enables it to easily handle even the most corrosive samples, such as those containing high levels of hydrofluoric acid (HF) or reactive organic solvents. The OpalMist is also capable of aspirating high concentrations of dissolved solids (typically up to 15%) without clogging. This makes the OpalMist the ideal nebulizer to handle geochemical samples which are typically dissolved in HF and are high in dissolved solids.

Other features of the OpalMist are:

- Excellent sensitivity – the small mean droplet size of the OpalMist increases transport efficiency without increasing noise.
- Excellent precision and long-term stability.
- Strong and consistent self-aspiration – available with natural uptake rates of 0.01, 0.05, 0.1, 0.2, 0.4, 0.6, 1 and 2mL/min. Self-aspiration eliminates the need for peristaltic pump tubing, a potential source of contamination.
- Suitable for all ICP-MS and ICP-OES models.
- The exacting quality and reproducibility standards you have come to expect from Glass Expansion.

For more information visit: www.glass.com/operational

GLASS EXPANSION
Quality By Design

Asia Pacific	Americas	Europe
6 Centre Boulevard, Burlington, MA 01803 USA Tel: +1 978 688 1111 www.glass.com	37 Leinster Avenue Drive, New Rochelle, NY 10801 USA Tel: +1 914 235 2200 www.glass.com	Princessway 1, Dunfermline Fife, KY11 1DQ UK Tel: +44 (0)1392 373333 www.glass.com

OpalMist Flyer

[Return to Contents Page](#)

Nebulizer Selection >

DC Nebulizers >

Nebulizer Types ✓

Seaspray

MicroMist

Conikal

Slurry

DuraMist

OpalMist

Ceramic VeeSpray

Nebulizer Selection Guide >

Nebulizer Maintenance >

Ceramic VeeSpray Nebulizer

Ideal for dirty samples

The Ceramic VeeSpray is the most rugged nebulizer. It can handle high dissolved solids and particulates without clogging and is suitable to all aqueous and organic solvents, even samples containing HF. It should be noted, however, that the VeeSpray is not a concentric nebulizer and therefore does not self-aspirate sample; it must be pumped. Because of this, pulsations from the peristaltic pump are more evident and this can degrade precision somewhat.

- Material: 99.8% Alumina Ceramic
- High physical reproducibility ~ 1%
- TDS tolerance, typically up to 30%
- High tolerance to particulates, typically up to 300µm
- Must be pumped – does not self-aspirate
- Design uptake range: 0.6 – 3mL/min. Operates best between 1.5 and 2.5mL/min

[More Information >](#)



Nebulizer Selection >

DC Nebulizers >

Nebulizer Types >

[Nebulizer Selection Guide](#) ✓

[For Aqueous Solutions without HF ICP-OES](#)

For Aqueous Solutions without HF ICP-MS

Solutions containing HF

Organic Solutions

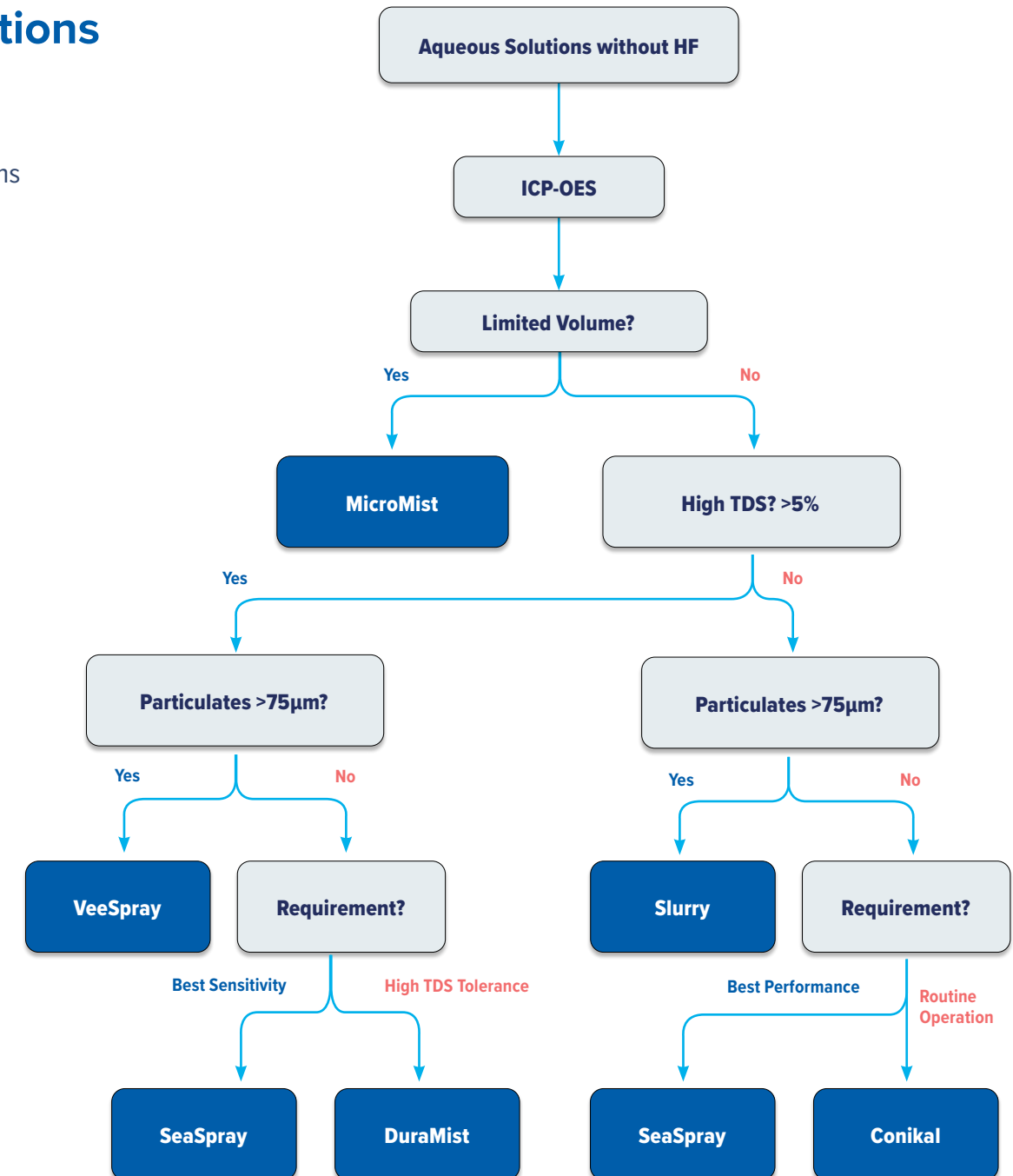
Nebulizer Maintenance >

Nebulizer Selection for Aqueous Solutions without HF - ICP-OES

This guide simplifies the nebulizer selection process for Aqueous Solutions without HF for ICP-OES.

Nebulizers for Aqueous Solutions without HF for ICP-OES:

- MicroMist
- SeaSpray
- Slurry
- Conikal
- VeeSpray
- DuraMist



Nebulizer Selection >

DC Nebulizers >

Nebulizer Types >

[Nebulizer Selection Guide](#) ✓

For Aqueous Solutions without HF
ICP-OES

[For Aqueous Solutions without HF
ICP-MS](#)

Solutions containing HF

Organic Solutions

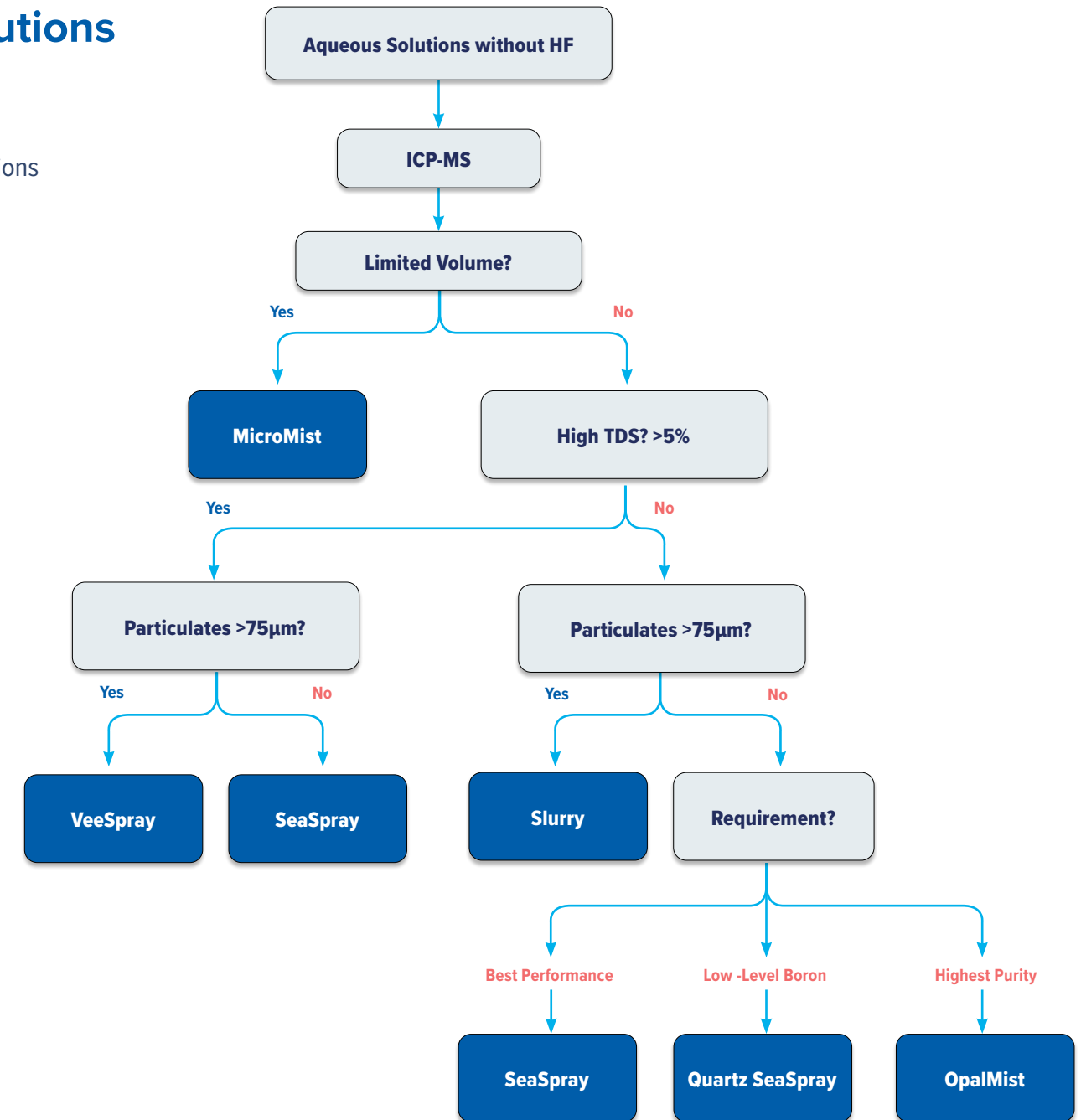
Nebulizer Maintenance >

Nebulizer Selection for Aqueous Solutions without HF - ICP-MS

This guide simplifies the nebulizer selection process for Aqueous Solutions without HF for ICP-MS.

Nebulizers for Aqueous Solutions without HF for ICP-MS:

- VeeSpray
- SeaSpray
- Slurry
- MicroMist
- Quartz SeaSpray
- OpalMist



Nebulizer Selection >

DC Nebulizers >

Nebulizer Types >

[Nebulizer Selection Guide](#) ✓

For Aqueous Solutions without HF
ICP-OES

For Aqueous Solutions without HF
ICP-MS

[Solutions containing HF](#)

Organic Solutions

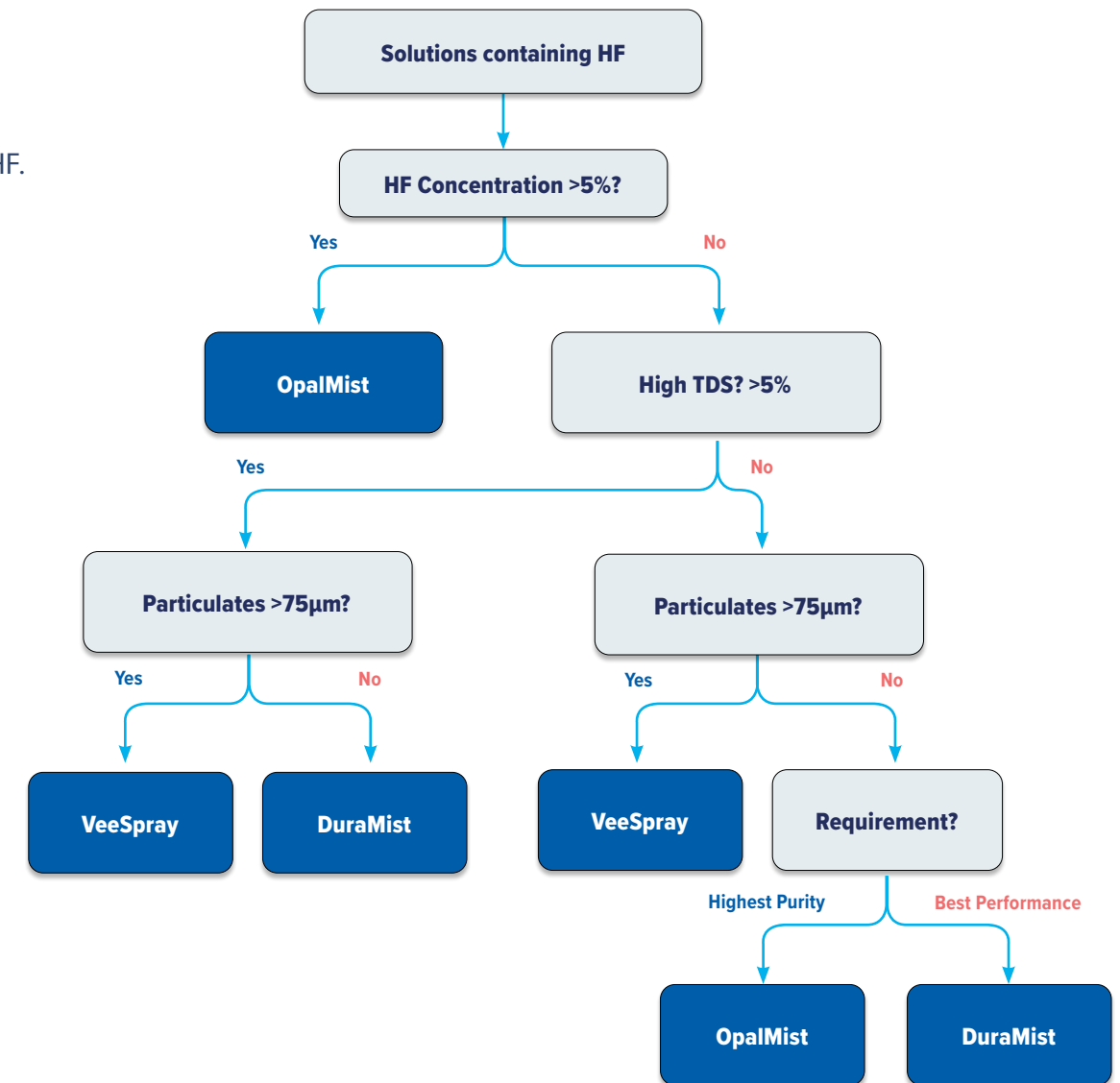
Nebulizer Maintenance >

Nebulizer Selection for Solutions containing HF

This guide simplifies the nebulizer selection process for samples containing HF.

Nebulizers for HF samples:

- OpalMist
- VeeSpray
- DuraMist



Nebulizer Selection >

DC Nebulizers >

Nebulizer Types >

[Nebulizer Selection Guide](#) ✓

For Aqueous Solutions without HF
ICP-OES

For Aqueous Solutions without HF
ICP-MS

Solutions containing HF

[Organic Solutions](#)

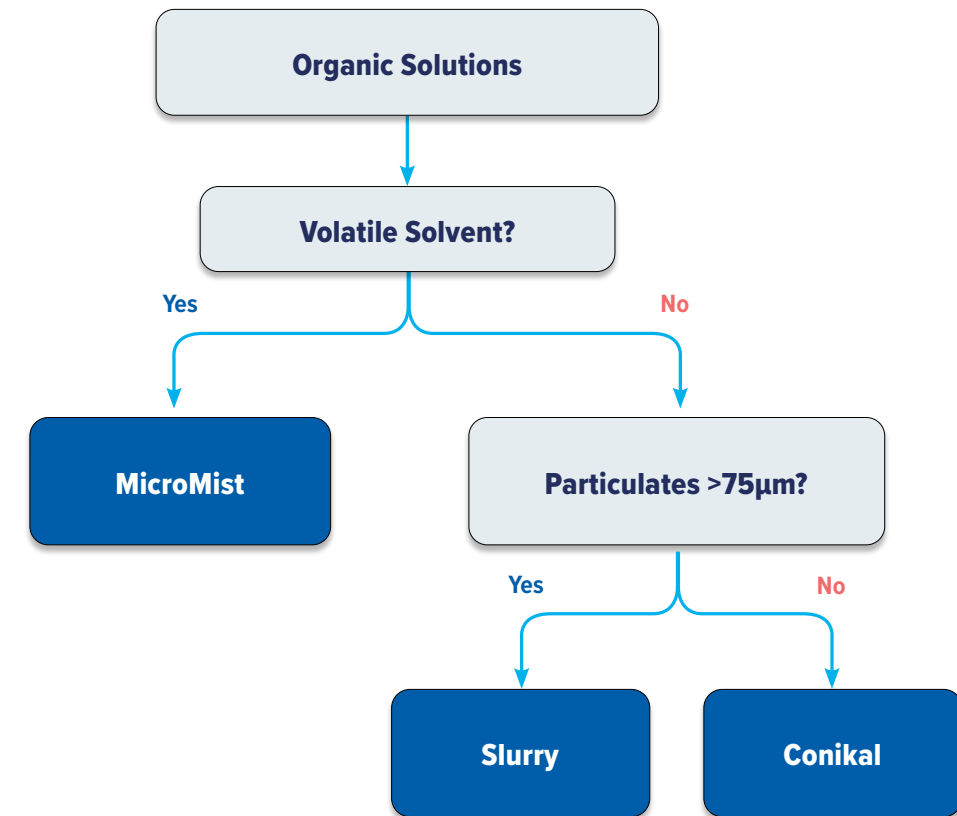
Nebulizer Maintenance >

Nebulizer Selection for Organic Solutions

This guide simplifies the nebulizer selection process for Organic Solutions.

Nebulizers for HF samples:

- Slurry
- MicroMist
- Conikal



Nebulizers

Nebulizer Selection >

DC Nebulizers >

Nebulizer Types >

Nebulizer Selection Guide >

Nebulizer Maintenance >

Eluo Nebulizer Cleaner

Eluo Models

Nebulizer Maintenance

Eluo™ Nebulizer Cleaner

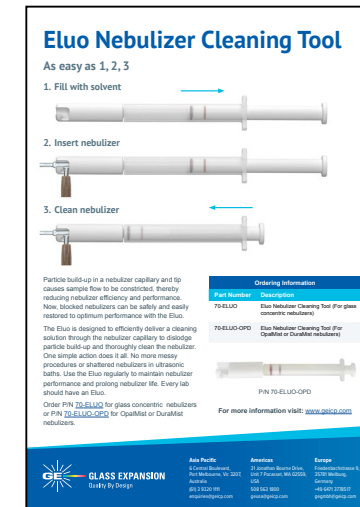
We cannot always accurately characterize the samples we analyze and sometimes we run samples with particulates on a nebulizer not well suited for them. The Eluo is a convenient tool for unclogging nebulizers if it is needed. Also, it is a good idea to routinely back-flush the nebulizer with the Eluo to avoid the buildup of any deposits at the orifice.

- Rugged plastic construction
- Large volume barrel
- Nebulizer locking mechanism
- Maintain nebulizers with daily cleaning

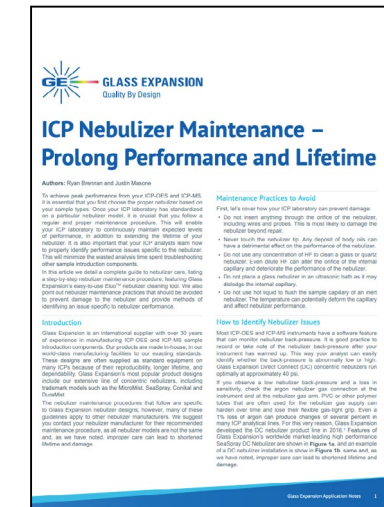
Eluo Operation

Easy as 1, 2, 3

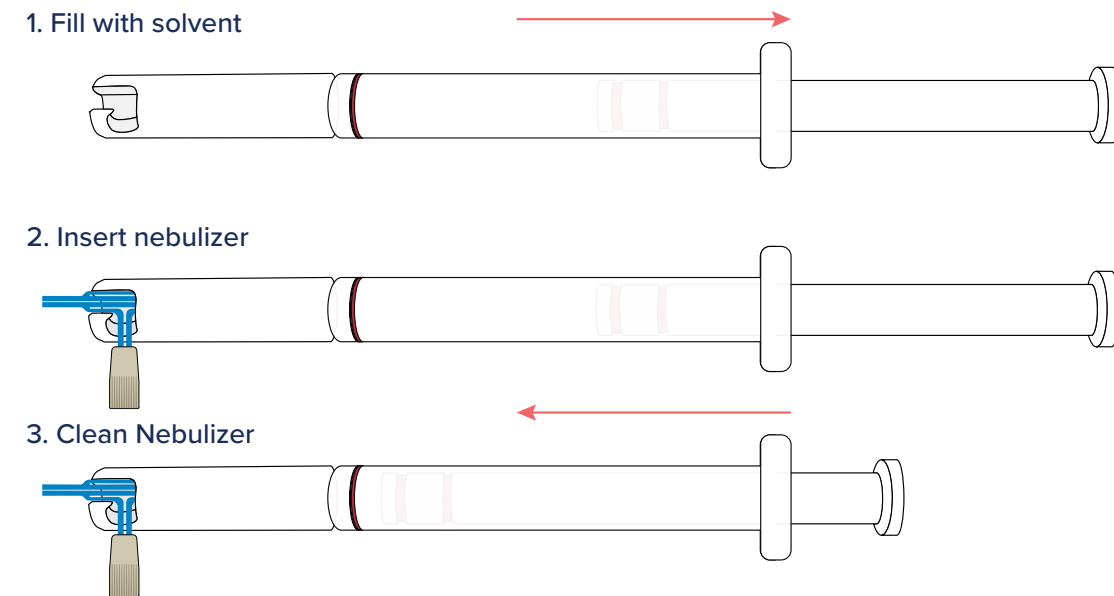
1. Fill the barrel with methanol
2. Insert nebulizer tip first and lock arm
3. Depress plunger to clean nebulizer



Eluo Flyer



ICP Nebulizer Maintenance - Application Note



< Return to Contents Page

Nebulizer Selection >

DC Nebulizers >

Nebulizer Types >

Nebulizer Selection Guide >

Nebulizer Maintenance ✓

Eluo Nebulizer Cleaner

Eluo Models

Eluo Models

The standard configuration, P/N 70-ELUO, accommodates all Glass Expansion concentric glass nebulizers, while Eluo-OPD is recommended for the OpalMist, PolyCon and, DuraMist. Because of its larger nebulizer holder, the Eluo-OPD will also accommodate other brands of concentric glass nebulizer. However, other brands have less rugged inner capillaries and are more easily damaged by applying the hydraulic pressure delivered by the Eluo.

It should be noted that a standard Eluo can be converted to an OPD configuration by purchasing just the OPD nebulizer holder P/N 70-803-0932.

The Eluo is available for Glass Expansion concentric glass and HF-resistant nebulizers.

Part Number	Description
70-ELUO	Eluo Nebulizer Cleaning Tool (glass concentric nebulizers)
70-ELUO-OPD	Eluo Nebulizer Cleaning Tool (OpalMist, PolyCon or DuraMist nebulizer)



Glass concentric nebulizer – requires 70-ELUO



OpalMist, PolyCon and DuraMist – requires 70-ELUO-OPD

[Spray Chamber Types](#) ▼

[Glass Spray Chambers](#)

[Inert Spray Chambers](#)

[DC High Efficiency Spray Chambers](#)

[HydraMist](#)

[Single-Cell Sample Introduction System](#)

[IsoMist XR](#)

[Peltier Cooled Cyclonic Spray Chamber](#)

[IsoMist-MS](#)

[Helix CT](#) ▶

[Spray Chamber Selection Guide](#) ▶

Spray Chamber Types

Glass Expansion offers a wide variety of spray chambers to accommodate all kinds of samples. The glass spray chambers are available in 4 different configurations while the inert chambers are made of either PFA or PTFE. The IsoMist and PCC can be configured with a spray chamber made of glass, quartz, or PFA.

- Glass Tracey – Cyclonic
- Glass Twister – Cyclonic with baffle
- Glass Cinnabar – Small volume cyclonic
- Glass Twinnabar – Small volume cyclonic with baffle
- PFA Tracey – HF resistant cyclonic for ICP-MS
- PTFE Tracey – HF resistant cyclonic for ICP-OES
- PTFE Twister - HF resistant cyclonic for ICP-OES
- DC High Efficiency Spray Chambers, Glass, PEEK
- HydraMist Simultaneous Cold Vapor/Pneumatic Nebulization Spray Chamber
- Single-cell Spray Chamber
- IsoMist XR Programmable Temperature Spray Chamber (Extended range)
- Peltier Cooled Cyclonic (PCC) Spray Chambers for the Agilent® ICP-MS Models
- IsoMist-MS, next generation spray chambers for Agilent ICP-MS models

[More Information](#) ▶

Spray Chambers

[Spray Chamber Types](#) ✓

[Glass Spray Chambers](#)

Inert Spray Chambers

DC High Efficiency Spray Chambers

HydraMist

Single-Cell Sample Introduction System

IsoMist XR

Peltier Cooled Cyclonic Spray Chamber

IsoMist-MS

[Helix CT](#) >

[Spray Chamber Selection Guide](#) >

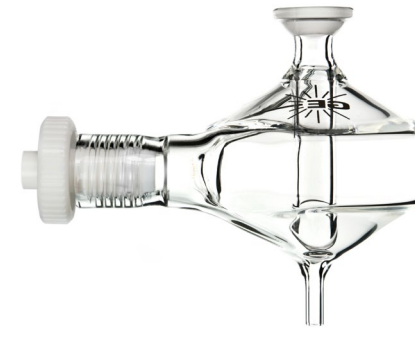
Glass Spray Chambers

This shows the distinctions between the glass spray chambers. The Tracey and the Twister are both standard volume (50mL) spray chambers and are recommended for most samples where the sample uptake rate is at least 0.4mL/min. The Twister has a built-in baffle or “knockdown” tube that serves as a droplet size cutoff filter and is recommended when stability and precision are key. The Tracey allows larger droplets to reach the plasma and will in general yield somewhat better sensitivity.

The Cinnabar and Twinnabar are analogous low volume (20mL) spray chambers and are recommended for fast washout when an uptake rate below 0.4mL/min is employed.



Tracey



Twister



Cinnabar



Twinnabar

Spray Chambers

[Spray Chamber Types](#) ✓

[Glass Spray Chambers](#)

Inert Spray Chambers

DC High Efficiency Spray Chambers

HydraMist

Single-Cell Sample Introduction System

IsoMist XR

Peltier Cooled Cyclonic Spray Chamber

IsoMist-MS

Helix CT >

Spray Chamber Selection Guide >

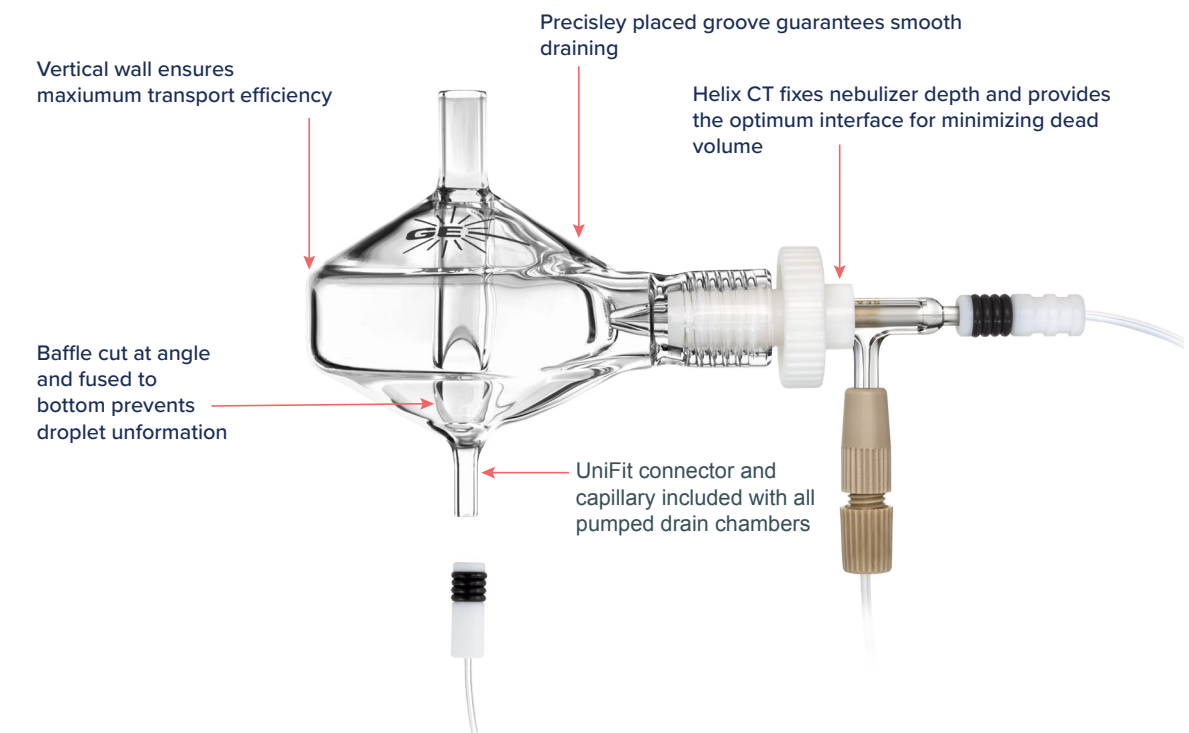
Glass Spray Chamber Details

Both the design and manufacture of cyclonic spray chambers are critical to the performance of your ICP. The Helix CT fitting not only eliminates the problems presented by o-rings but also is carefully designed to fix the depth of penetration of a Glass Expansion nebulizer so that the aerosol produced is optimum.

An indented groove is built into the top of the spray chamber and serves as a barrier preventing the solution from being swept into the torch. The position and depth of this groove are critical.

Note that the walls of the chamber have a vertical region. This is important for proper aerosol generation and affects transport efficiency to the torch.

The knock-out tube or baffle is cut at an angle and carefully positioned to maximize transport of the aerosol but minimize transport of large droplets. All pumped spray chambers include a UniFit connector & capillary for smooth and efficient draining.



[More Information >](#)

Spray Chamber Types

Glass Spray Chambers

[Inert Spray Chambers](#)

DC High Efficiency Spray Chambers

HydraMist

Single-Cell Sample Introduction System

IsoMist XR

Peltier Cooled Cyclonic Spray Chamber

IsoMist-MS

[Helix CT](#)

[Spray Chamber Selection Guide](#)

Inert Spray Chambers

We offer inert spray chambers in two materials. PTFE is used for ICP-OES applications, while, due to its high purity, PFA is used for ICP-MS applications. In both cases, the interior of the chamber undergoes our Stediflow surface treatment which improves the wettability of the surface and ensures efficient drainage. Without the Stediflow treatment, droplets tend to form on the surface and degrade both sensitivity and precision.

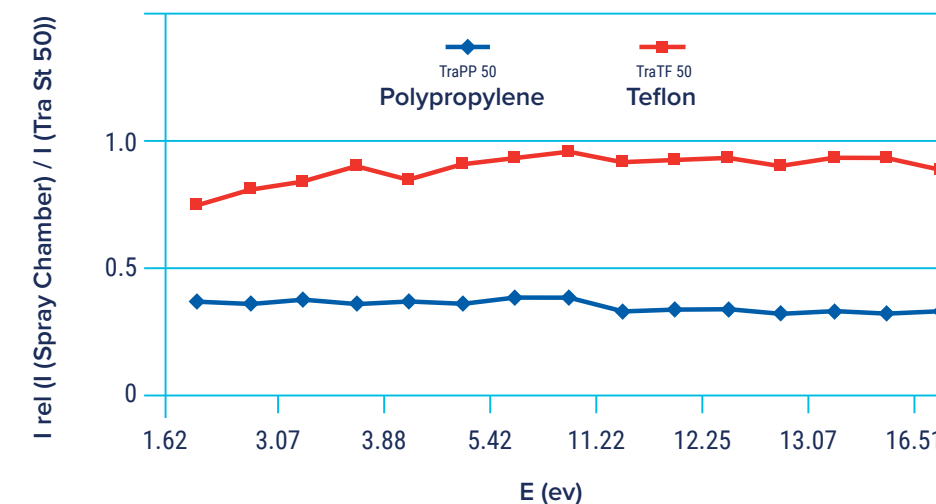
ICP-OES

- PTFE Material
 - * Inert
 - * High purity
 - * Stediflow surface treatment
- 50mL internal volume
- Tracey and Twister models available



ICP-MS

- PFA Material
 - * Inert
 - * Ultra high purity
 - * Stediflow surface treatment
- 44mL internal volume



Sensitivity

Dr. Canals at the University of Alicante in Spain, in collaboration with Glass Expansion, undertook a detailed study of spray chamber material and design. The graph above shows just some of that data and particularly the comparison of the current design to the previous polypropylene design. Both spray chambers were compared to the best performing glass spray chamber. Note that the sensitivity has doubled with the current design and gives close to the same performance as the glass chamber. Although not shown here, precision also was improved with the Teflon material.

[Spray Chamber Types](#)



Glass Spray Chambers

Inert Spray Chambers

[DC High Efficiency Spray Chambers](#)

HydraMist

Single-Cell Sample Introduction System

IsoMist XR

Peltier Cooled Cyclonic Spray Chamber

IsoMist-MS

[Helix CT](#)

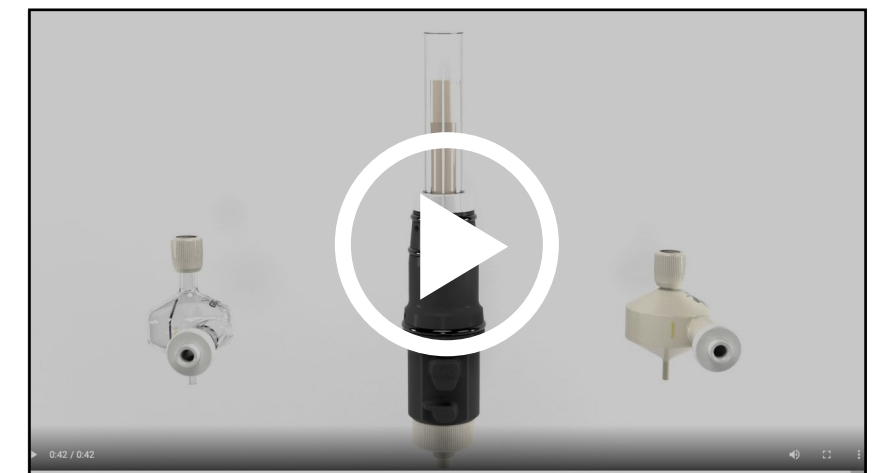
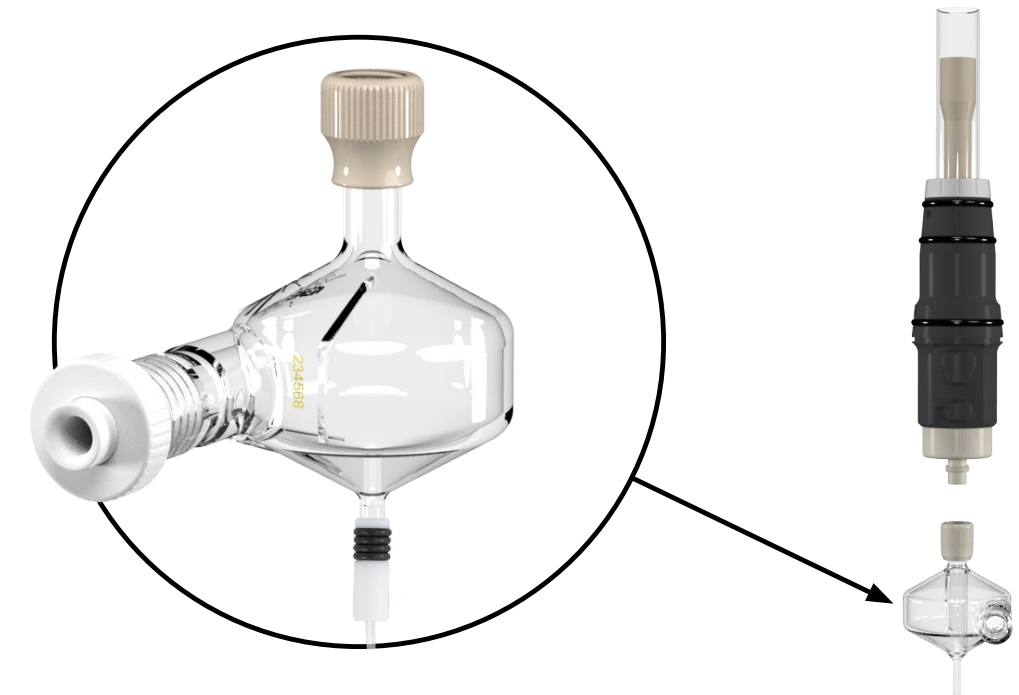


[Spray Chamber Selection Guide](#)



High Efficiency Direct Connect (DC) Spray Chambers

- No o-rings.
- DC connection is inert all PEEK construction.
- Eliminates ball joint clamps that rust over time.
- Guarantees perfect alignment each and every time for improved precision and better transport efficiency.
- Tracey™ DC Spray chamber design is available in Glass, PEEK, PFA and Quartz material.
- Low volume (30mL) cyclonic spray chamber for faster washout with Helix CT technology.



DC Spray Chamber Video

Spray Chambers

Introduction

Nebulizers

Spray Chambers

Torches

RF Coils

Cones

Accessories

Fittings & Connectors

Summary

Spray Chamber Types

Glass Spray Chambers

Inert Spray Chambers

DC High Efficiency Spray Chambers

HydraMist

Single-Cell Sample Introduction System

IsoMist XR

Peltier Cooled Cyclonic Spray Chamber

IsoMist-MS

Helix CT

Spray Chamber Selection Guide



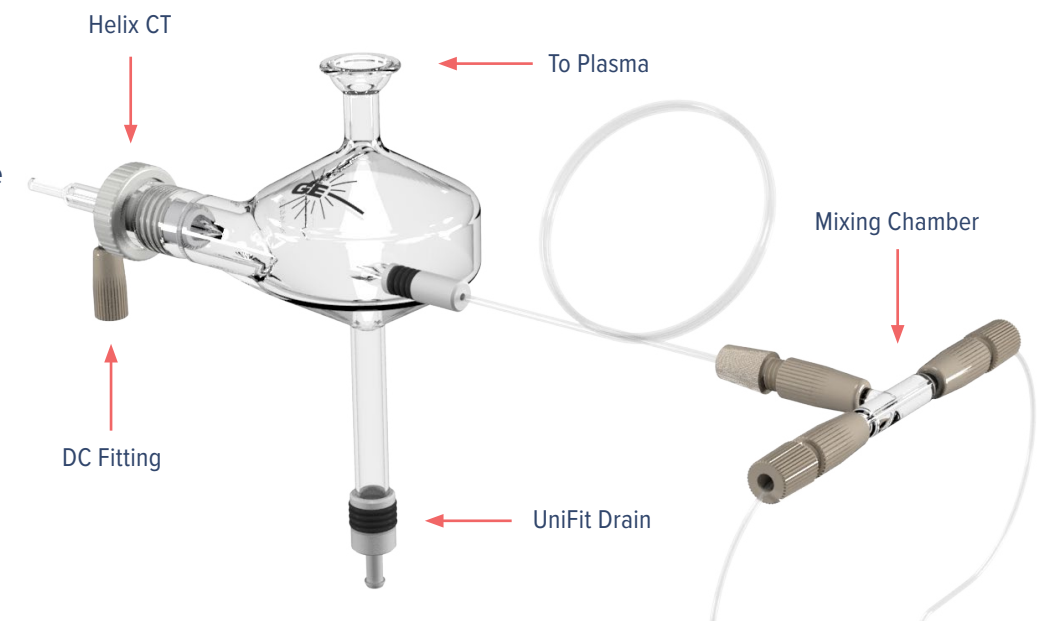
HydraMist Simultaneous Cold Vapor/Pneumatic Nebulization Spray Chamber

The Glass Expansion HydraMist is a sensitive, simple-to-use spray chamber for ICP that allows simultaneous operation of both conventional pneumatic nebulization and cold-vapor/hydride generation. Cold vapor generation can provide more than 10-fold improvement in sensitivity on ICP for cold vapor forming elements such as As, Sb, Se, Tl and Hg. The generation of volatile species of these elements results in increased analyte loading of the analytical plasma giving lower detection limits.

The design of the HydraMist spray chamber is based upon Glass Expansion's industry-standard cyclonic spray chamber, giving excellent sensitivity and short-term analytical precision with fast washout. The HydraMist spray chamber features a secondary inlet port that mixes the aerosolized sample and liquid reductant inside the spray chamber for rapid conversion of the As, Sb, Se, Tl, and Hg analytes into volatile hydride species. The unique drain design ensures fast, complete removal of waste from the spray chamber, eliminating excess hydrogen build-up that causes sample reflux degrading analytical precision.

Features

- The same outstanding short-term analytical precision and washout as other Glass Expansion cyclonic spray chambers
- Fast and complete vapor phase formation of volatile As, Se, Sb, Tl, and Hg species for the best detection limits in hydride generation mode
- A unique drain design to eliminate hydrogen build-up and sample reflux that degrades short-term precision
- Economic, just replace your current spray chamber and keep your existing nebulizer
- Improve productivity by analyzing non-hydride forming elements and cold vapor elements simultaneously, avoiding system shutdowns to change over between the hydride generator accessory and conventional pneumatic nebulization



HydraMist Flyer

[More Information >](#)

[Return to Contents Page](#)

Spray Chambers

[Spray Chamber Types](#)



Glass Spray Chambers

Inert Spray Chambers

DC High Efficiency Spray Chambers

[HydraMist](#)

Single-Cell Sample Introduction System

IsoMist XR

Peltier Cooled Cyclonic Spray Chamber

IsoMist-MS

[Helix CT](#)



[Spray Chamber Selection Guide](#)



HydraMist - Modes

With a simple setup and fast changeover, the HydraMist Spray chamber can be operated in one of 3 different modes.

The simple mode provides (Figure 1.) simultaneous hydride and pneumatic nebulization mode with 5 fold improvements for detection limits of the hydride forming elements while maintaining analytical performance for non-hydride elements.

With the addition of an extra sample input and t-piece (Figure 2.) the HydraMist provides a sensitive, simultaneous cold vapor and pneumatic nebulization mode with more than 10 fold improvements in detection limits for the cold vapor elements without compromising the performance of non-hydride forming elements. Finally, it can be used as a conventional cyclonic spray chamber with pneumatic nebulization.

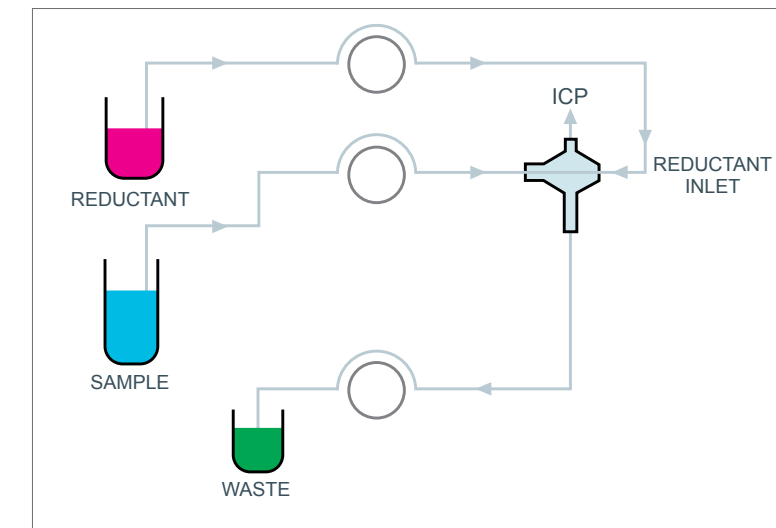


Figure 1. Simple simultaneous cold vapor/pneumatic nebulization mode

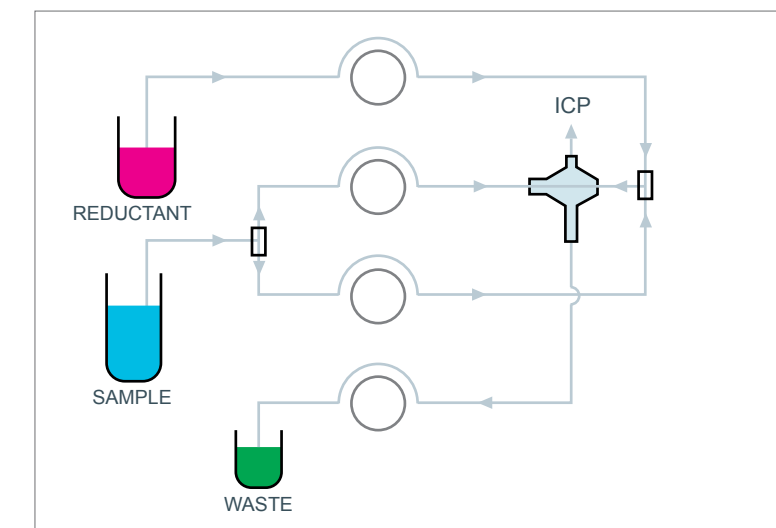


Figure 2. Sensitive simultaneous cold vapor/pneumatic nebulization mode

Spray Chambers

[Spray Chamber Types](#) ▼

Glass Spray Chambers

Inert Spray Chambers

DC High Efficiency Spray Chambers

[HydraMist](#)

Single-Cell Sample Introduction System

IsoMist XR

Peltier Cooled Cyclonic Spray Chamber

IsoMist-MS

Helix CT ➤

Spray Chamber Selection Guide ➤

HydraMist - Modes

Table 1. Measured 3 σ detection limits (in $\mu\text{g/L}$) with an Agilent Technologies® 5100 SVDV in axial mode at 1.4 kW RF power and 20 second integration time

Element	Pneumatic Nebulization	Sensitive simultaneous hydride/pneumatic nebulization mode	Simple simultaneous hydride/pneumatic nebulization mode
Wavelength λ	($\mu\text{g/L}$)	($\mu\text{g/L}$)	($\mu\text{g/L}$)
As 188	3.7	0.2	0.5
Hg 194	1.2	0.07	0.1
Sb 206	3.6	0.2	0.4
Se 196	2.9	0.2	0.5
Cd 214	0.1	0.1	0.1
Co 238	0.4	0.5	0.7
Cr 267	0.5	0.3	0.3
Cu 327	0.5	0.6	0.6
Fe 238	0.4	0.3	0.4
Mn 257	0.05	0.04	0.03
Mo 202	0.5	0.7	0.7
Ni 231	0.7	1.0	1.0
Pb 220	1.9	2.3	2.6
Tl 190	2.1	0.2	0.2
Zn 213	0.2	0.2	0.2

Spray Chambers

Spray Chamber Types

- Glass Spray Chambers
- Inert Spray Chambers
- DC High Efficiency Spray Chambers
- HydraMist
- [Single-Cell Sample Introduction System](#)
- IsoMist XR
- Peltier Cooled Cyclonic Spray Chamber
- IsoMist-MS

Helix CT

Spray Chamber Selection Guide

Enhanced Single Cell Sample Introduction System for ICP-MS

Single-cell analysis using an Inductively Coupled Plasma-Mass Spectrometer (SC-ICP-MS) is enhancing the fundamental understanding of cellular biology, oncology, and drug discovery. SC-ICP-MS provides for the quantification of metals in individual biological cells and is used as a research tool to allow scientists to study disease aetiology, better understand diseased cell states and develop new drug treatments to give better patient outcomes.

In single-cell analysis, the sample introduction system converts a continuous stream of biological cells efficiently into an aerosol of individual cells and transfers the aerosol into the Inductively Coupled Plasma of the ICP-MS for analysis. A critical aspect of the sample introduction system is the cells must remain intact and unruptured during the nebulization process to ensure each individual cell produces a single ion burst inside the plasma that can be transferred into the mass analyzer of the ICP-MS for quantification.

Conventional ICP-MS spray chambers have low transport efficiencies (typically < 5% TE) that filter out larger droplets (> 5µm) from the nebulizer aerosol. As most cell lines of interest are larger than 5µm, the secondary filtering mechanism of conventional spray chamber designs rejects a high proportion of the cells from passing to the plasma. To overcome this significant deficiency the Glass Expansion spray chamber design for single-cell analysis is different from conventional ICP-MS spray chambers.

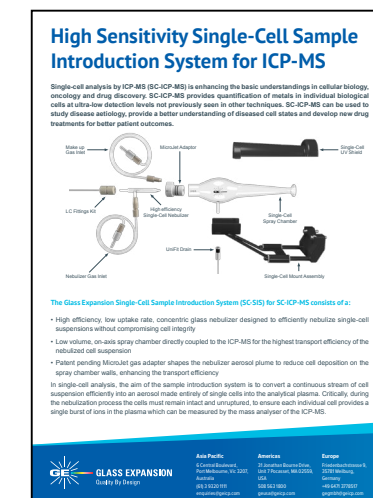
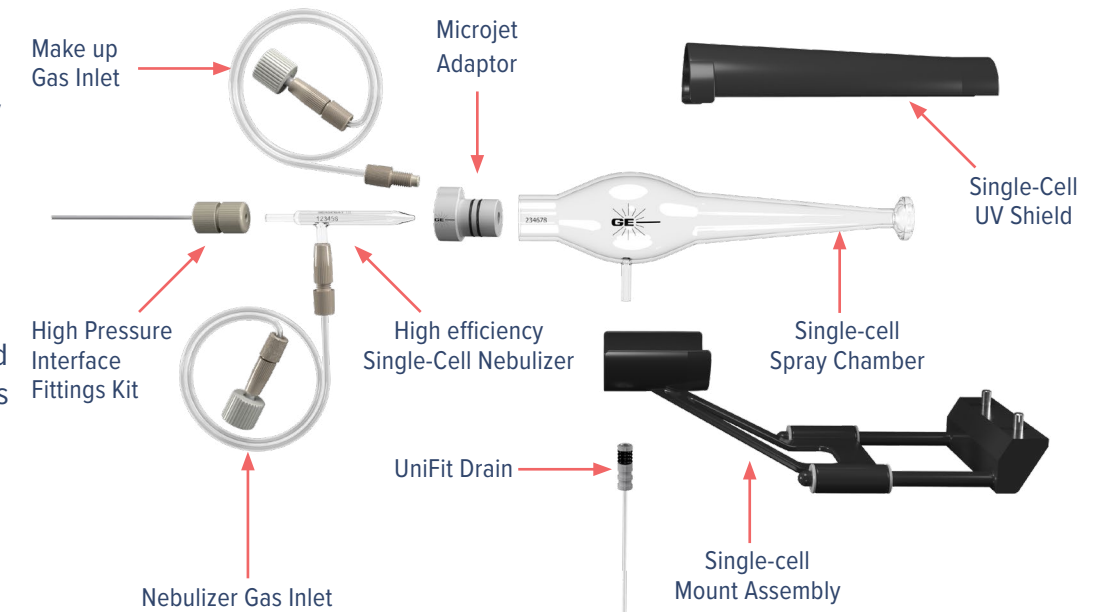
Single-cell Literature

[High-Sensitivity Single-Cell Sample Introduction System for ICP-MS](#)

[High Efficiency Nebulizer for Single Cell TOF-ICP-MS Presentation Poster](#)

[Multi-ELEMENT Analysis of Single Cells using a TOF-ICP-MS](#)

[Towards Automated Routine Analysis of the Distribution of Trace Elements in Single Cells using ICP-MS](#)



Single Cell Flyer

[More Information](#)

[Return to Contents Page](#)

[Spray Chamber Types](#) ✓

Glass Spray Chambers

Inert Spray Chambers

DC High Efficiency Spray Chambers

HydraMist

[Single-Cell Sample Introduction System](#)

IsoMist XR

Peltier Cooled Cyclonic Spray Chamber

IsoMist-MS

[Helix CT](#) >

[Spray Chamber Selection Guide](#) >

Enhanced Single Cell Sample Introduction System for ICP-MS

Features

- High efficiency, low uptake, concentric glass nebulizer designed to efficiently nebulize single-cell suspensions without compromising cell integrity
- Low volume, on-axis, laminar-flow spray chamber directly coupled to the ICP for the highest transport efficiency of the nebulized single-cell suspension
- Patent-pending MicroJet gas adapter which entrains and shapes the aerosol plume to reduce cell deposition onto the spray chamber walls and increase sample transport efficiency

High Efficiency Single Cell Nebulizer

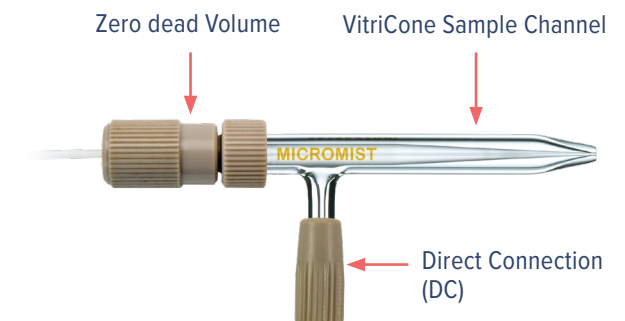
Features

- Superb transport efficiency at low sample uptake rates (15 to 45 $\mu\text{L}/\text{min}$) to ensure individual intact cells are transported into the plasma for measurement
- Constant diameter, large-bore sample channel minimizes blockages from sample build-up commonly experienced with biological samples
- Rigid, precision machined thick-walled glass sample capillary gives the best analytical precision by resisting harmonic vibrations from the high linear velocity of the surrounding argon gas flow
- Inert, metal-free DC gas fittings with ratchet mechanism give reliable, reproducible leak-free Ar connections

Spray Chamber with MicroJet Adaptor

Features

- Superb transport efficiency at low sample uptake rates (15 to 45 $\mu\text{L}/\text{min}$) to ensure individual intact cells are transported into the plasma for measurement
- Constant diameter, large-bore sample channel minimizes blockages from sample build-up commonly experienced with biological samples
- Rigid, precision machined thick-walled glass sample capillary gives the best analytical precision by resisting harmonic vibrations from the high linear velocity of the surrounding argon gas flow
- Inert, metal-free DC gas fittings with ratchet mechanism give reliable, reproducible leak-free Ar connections



[Spray Chamber Types](#) ✓

Glass Spray Chambers

Inert Spray Chambers

DC High Efficiency Spray Chambers

HydraMist

Single-Cell Sample Introduction System

[IsoMist XR](#)

Peltier Cooled Cyclonic Spray Chamber

IsoMist-MS

Helix CT >

Spray Chamber Selection Guide >

IsoMist XR Programmable Temperature Spray Chamber

The IsoMist XR is a Programmable Temperature Spray Chamber with the features shown. It incorporates a cyclonic spray chamber which is encapsulated in a conductive material to enhance heat transfer.

So far, we have discussed only those spray chambers that operate at room temperature. One consideration of these is that, as the room temperature changes, so does that of the spray chamber and that affects the transport efficiency and hence the sensitivity, resulting in analyte drift. Another concern is that specific sample matrices, particularly those which are very volatile, excessively load the plasma, resulting in instability and, in the worst case, extinguish the plasma.

For ICP-MS applications, excessive oxide formation can occur at room temperature, leading to isobaric interferences which must be dealt with. In summary, a room temperature spray chamber affords little control over analyte transport to the torch.

Features

- Programmable from -25 to 80°C in 1°C increments
- Maintains temperature to within 0.1°C
- Compact design
- 100% self-contained (no external lines)
- Incorporates Bluetooth® technology for clean wireless control (USB available)
- Compatible with all ICP-OES and ICP-MS models
- Time taken to pass below 0°C from 25°C <15 minutes

Benefits

- Enables the analysis of volatile organics
- Enhances sensitivity for limited volume samples
- Reduces isobaric oxide interferences
- Increases the chance of passing QC checks
- Provides a record for regulatory compliance
- Eliminates drift (2°C change equals 10% shift in sensitivity)



[Spray Chamber Types](#) ✓

Glass Spray Chambers

Inert Spray Chambers

DC High Efficiency Spray Chambers

HydraMist

Single-Cell Sample Introduction System

[IsoMist XR](#)

Peltier Cooled Cyclonic Spray Chamber

IsoMist-MS

Helix CT >

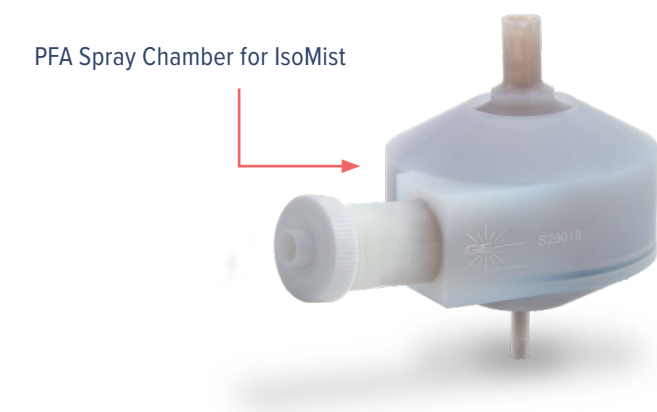
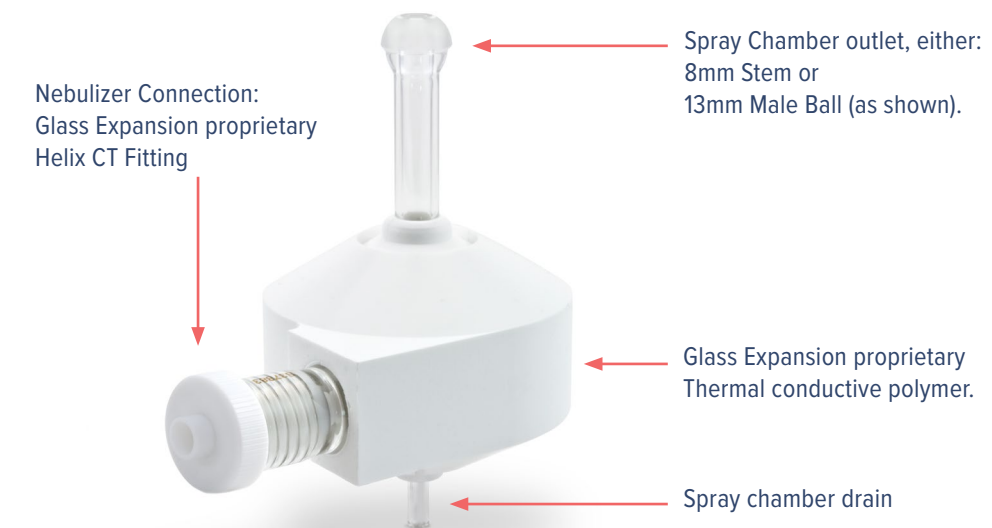
Spray Chamber Selection Guide >

IsoMist XR Configurations

Each IsoMist is customized for the particular make and model of ICP or ICP-MS with which it will be used. In some instances, the nebulizer will be on the left and others on the right side of the accessory. The standard configuration includes a glass Twister spray chamber, but the IsoMist can be ordered with either a quartz or PFA spray chamber. And if you want to use more than one type of chamber, no problem; they are completely interchangeable. The IsoMist can also be supplied with a low volume Twinnabar spray chamber but this is not interchangeable with the other spray chambers.

- Standard glass cyclonic Twister spray chamber; e.g. KT-1013-XR
- Quartz cyclonic Twister spray chamber; e.g. KT-1013Q-XR
- High purity PFA cyclonic spray chamber; e.g. KT-1013P-XR
- Low volume Twinnabar spray chamber; e.g. KT-1013T-XR
- Glass, quartz, and PFA spray chambers are interchangeable

[More Information](#) >



Spray Chambers

Spray Chamber Types



- Glass Spray Chambers
- Inert Spray Chambers
- DC High Efficiency Spray Chambers
- HydraMist
- Single-Cell Sample Introduction System
- IsoMist XR**
- Peltier Cooled Cyclonic Spray Chamber
- IsoMist-MS

Helix CT ➤

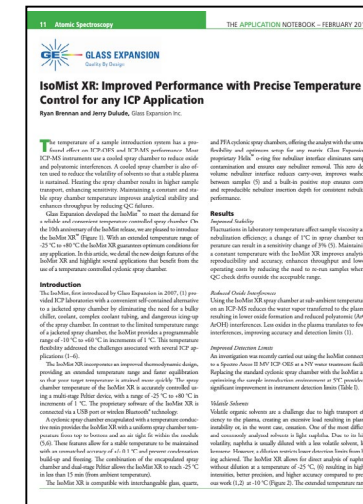
Spray Chamber Selection Guide ➤

IsoMist XR with Thermo® 6500 Duo ICP

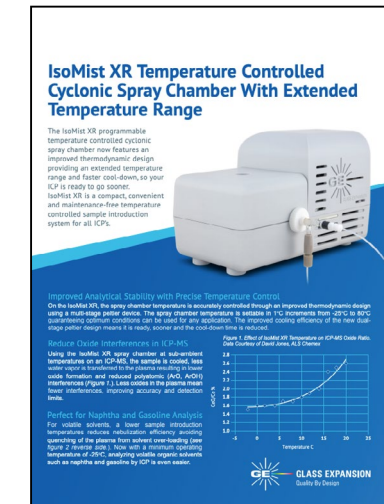
Trace metal content in naphtha is important for a number of reasons. The presence of metals such as nickel during the cracking process can poison the expensive catalyst, while vanadium causes corrosion problems. During the refining process, the release of toxic metals such as lead, mercury, and arsenic must be monitored and minimized. The presence of trace metals is also used to gain insight into the geological origin and migration of crude oil to aid in exploration.

The analysis of naphtha by ICP-OES is complicated by the high volatility of the sample, which can overload the plasma. It is therefore often diluted with a suitable solvent such as kerosene or xylene to facilitate the analysis. Unfortunately, due to the low levels of detection desired, dilution may not always be a viable course of action.

The instrument parameters and configuration employed	
Torch	D-Torch with alumina inner tube and ceramic outer tube
Injector	Quartz tapered 1.0mm bore
Nebulizer	SeaSpray glass concentric with 0.4mL/min uptake
Pump tubing	Contour Flared-end Solva two tag, Orange/Yellow 0.51mm ID
Plasma gas flow rate (L/min)	16
Auxiliary gas flow rate (L/min)	2
Forward Power (watts)	1350
Nebulizer gas flow rate (L/min)	0.28
Sample uptake rate (mL/min)	0.5
Spray chamber temperature (°C)	-10 and -25



IsoMist XR - Application Note



IsoMist XR Flyer

Spray Chamber Types

Glass Spray Chambers

Inert Spray Chambers

DC High Efficiency Spray Chambers

HydraMist

Single-Cell Sample Introduction System

IsoMist XR

Peltier Cooled Cyclonic Spray Chamber

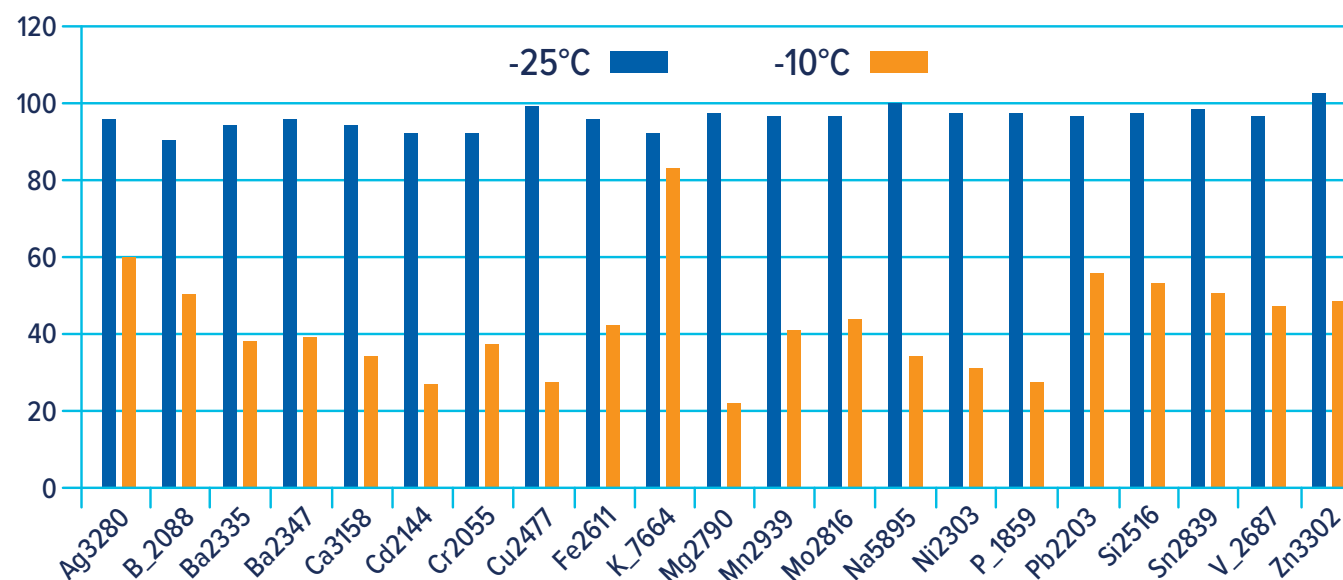
IsoMist-MS

Helix CT

Spray Chamber Selection Guide

Effect of Spray Chamber Temperature on Intensity

It is generally regarded that an oxide ratio of less than 2% is desirable to provide a more robust system. Even instruments that use collision/reaction cells to reduce oxide and other molecular isobaric interferences benefit from a reduced oxide ratio. In this experiment, it was found that using an IsoMist XR temperature of 2°C was optimum.



Oxide Reduction in ICP-MS

Isobaric oxide interferences

For ICP-MS, there are a number of oxides that can interfere with specific masses as shown, resulting in the reporting of false positives.

Element / Isotope	Interface
⁵⁶ Fe	⁴⁰ Ar ¹⁶ O+
⁵¹ V+	³⁵ Cl ¹⁶ O+
⁴⁴ Ca+	¹⁴ N ¹⁴ N ¹⁶ O+
⁴⁸ Ti+	³² S ¹⁶ O+
⁵² Cr+	³⁴ S ¹⁸ O+
⁶⁴ Zn+	³² S ¹⁶ O ¹⁶ O+
⁶⁴ Zn+	⁴⁸ Ca ¹⁶ O+

Spray Chambers

[Spray Chamber Types](#)



Glass Spray Chambers

Inert Spray Chambers

DC High Efficiency Spray Chambers

HydraMist

Single-Cell Sample Introduction System

[IsoMist XR](#)

Peltier Cooled Cyclonic Spray Chamber

IsoMist-MS

Helix CT



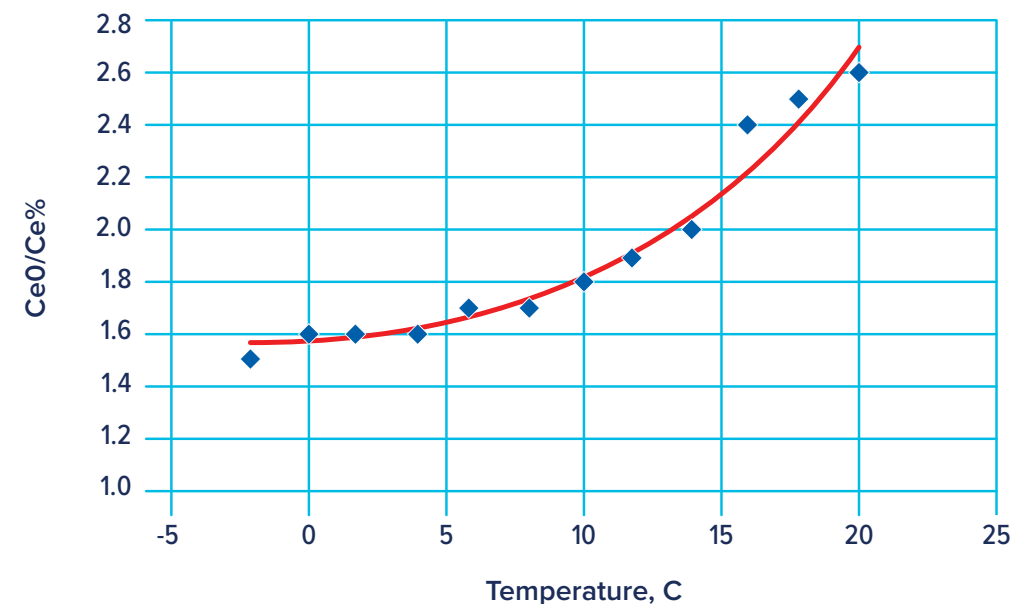
[Spray Chamber Selection Guide](#)



Reducing Oxides for ICP-MS

Effect of IsoMist XR Temperature

It is generally regarded that an oxide ratio of less than 2% is desirable to provide a more robust system. Even instruments that use collision/reaction cells to reduce oxide and other molecular isobaric interferences benefit from a reduced oxide ratio. In this experiment, it was found that using an IsoMist XR temperature of 2°C was optimum.



Analysis of Limited Sample Volumes

Another application of the IsoMist XR, involving heating rather than cooling of the spray chamber, relates to the analysis of small sample volumes such as is sometimes the case in the clinical analysis of intracellular fluids and neonatal blood and serum samples. Forensic labs are often challenged to harvest as much information as possible from a very small specimen. Also, where waste is very expensive to dispose of, as is the case with radioactive or very toxic samples, minimizing sample uptake minimizes waste. In each of these cases, the analyst is charged with the task of attaining valid analytical data often at very low concentrations making dilution an untenable alternative.

- Biological applications
- Intracellular fluids
- Neonatal samples
- Forensic applications
- Waste reduction applications
- Radioactive samples
- Toxic samples
- Requires micro-flow nebulization
- Sensitivity and DL's usually sacrificed

Spray Chambers

[Spray Chamber Types](#) ▼

Glass Spray Chambers

Inert Spray Chambers

DC High Efficiency Spray Chambers

HydraMist

Single-Cell Sample Introduction System

[IsoMist XR](#)

Peltier Cooled Cyclonic Spray Chamber

IsoMist-MS

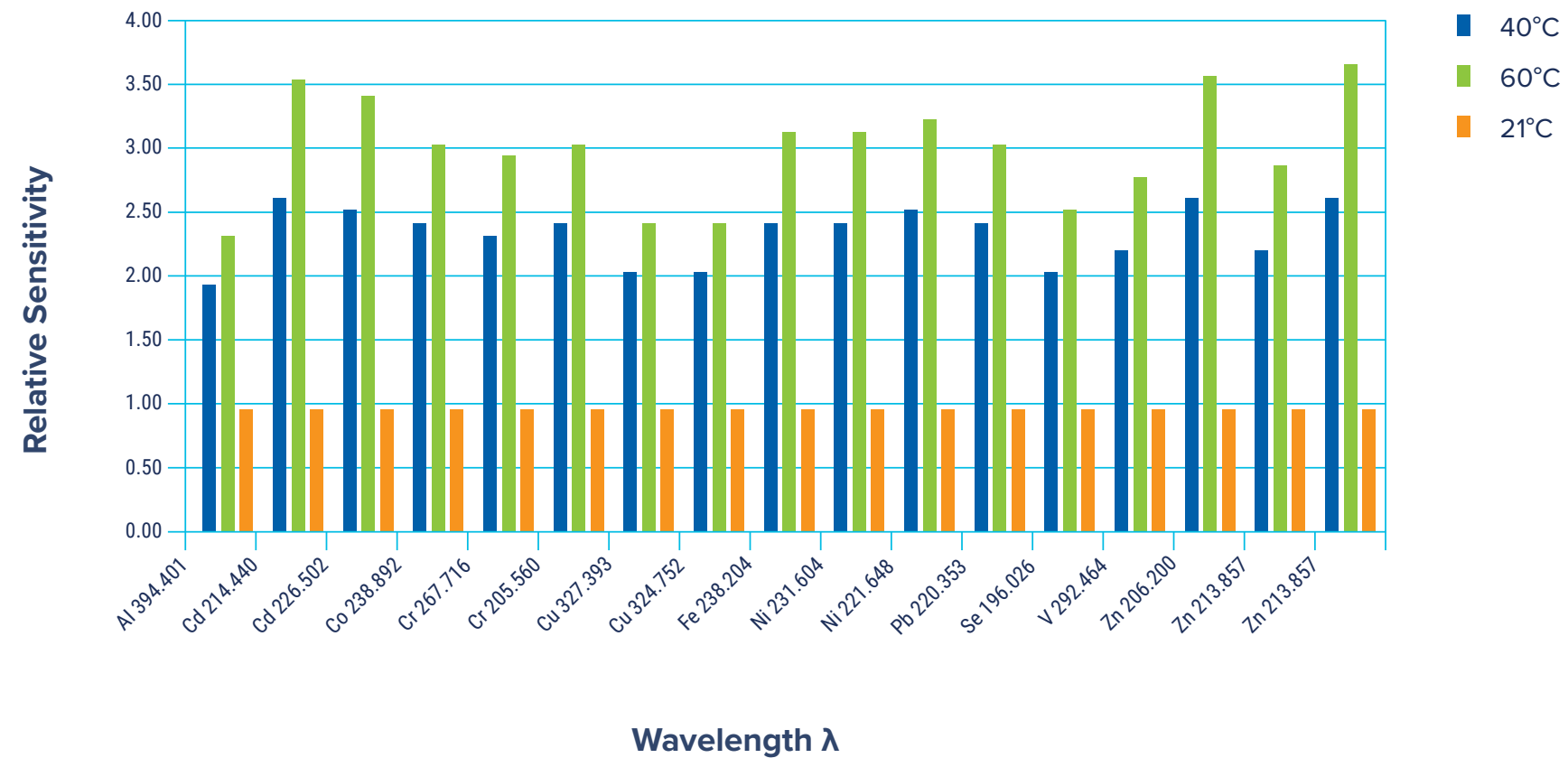
[Helix CT](#) ▶

[Spray Chamber Selection Guide](#) ▶

Effect of Temperature on Normalized Sensitivity

(20 μ L/min uptake)

In this experiment, a 20 μ L/min sample uptake rate was used to conserve sample. Using the IsoMist XR, sensitivity for aqueous standards was determined at 3 different temperatures, 21 (room temperature), 40, and 60°C. Data was normalized to the 21°C results. Note that at 40°C, sensitivity was double that at 21°C and that at 60°C, triple. This is significant in that by heating the spray chamber to 60°C, we can achieve 3 times more sensitivity without consuming more sample; more and better information without the cost of more sample.



Spray Chamber Types

Glass Spray Chambers

Inert Spray Chambers

DC High Efficiency Spray Chambers

HydraMist

Single-Cell Sample Introduction System

IsoMist XR

Peltier Cooled Cyclonic Spray Chamber

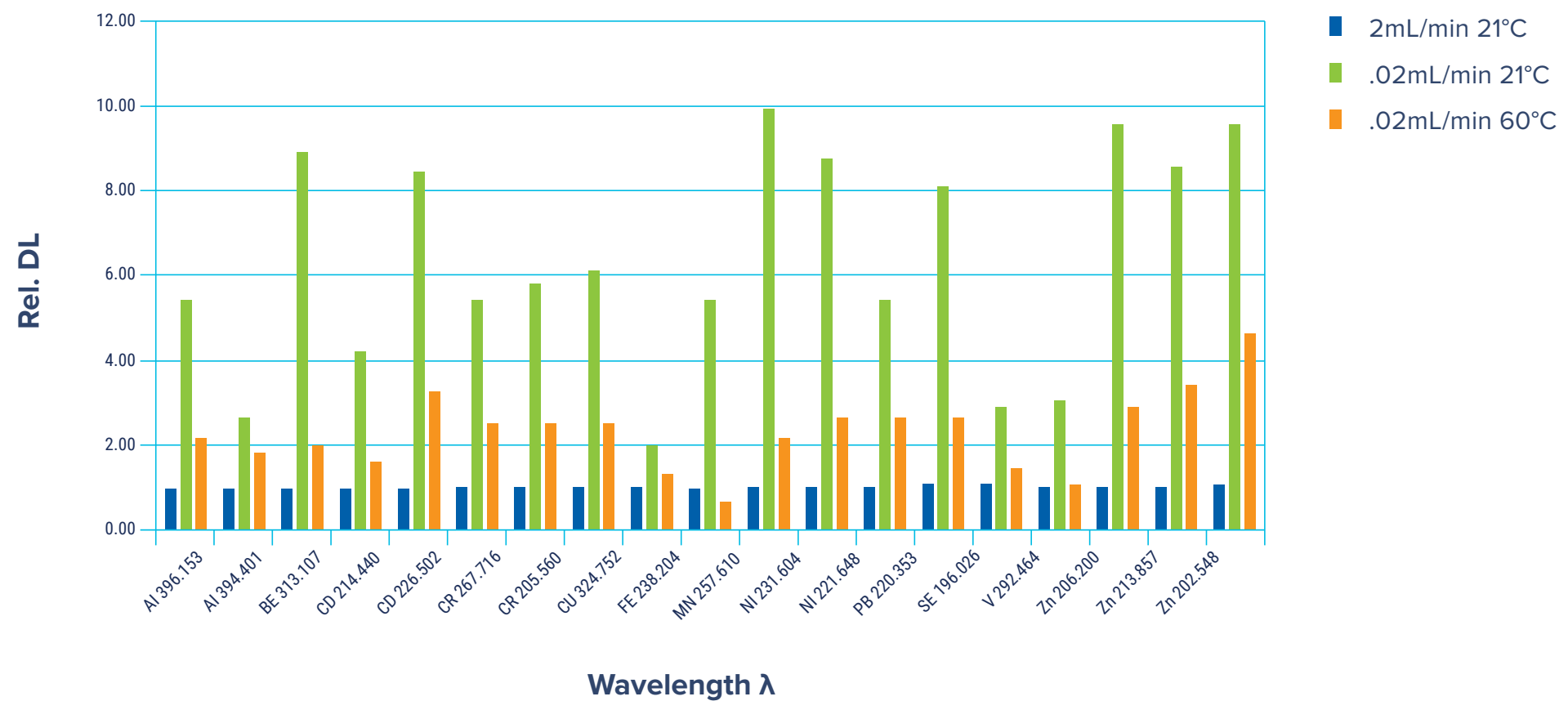
IsoMist-MS

Helix CT

Spray Chamber Selection Guide

Effect of Temperature on DL

We also determined detection limits for these analytes under the same conditions. In this case, data was normalized to that attained at 21°C but with the standard uptake rate of 2mL/min (blue). The green bars show the degradation in detection limits resulting from changing to 20µL/min also at 21°C, about a factor of 4 to 10. The orange bars give the degradation in detection limits achieved when 20µL/min was run at 60°C. Note that now, only a factor of 2 to 3 is sacrificed and in some cases, there is no degradation at all.



Spray Chambers

[Spray Chamber Types](#)

Glass Spray Chambers

Inert Spray Chambers

DC High Efficiency Spray Chambers

HydraMist

Single-Cell Sample Introduction System

[IsoMist XR](#)

Peltier Cooled Cyclonic Spray Chamber

IsoMist-MS

Helix CT

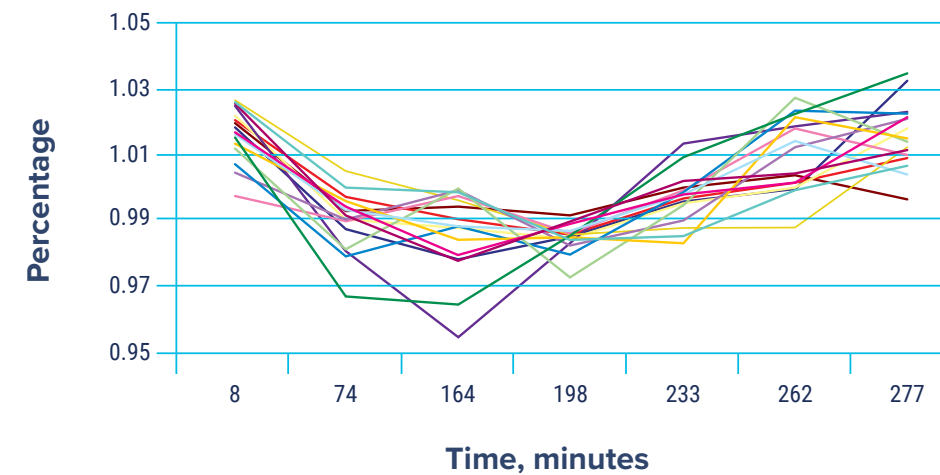
Spray Chamber Selection Guide

Constant temperature benefits

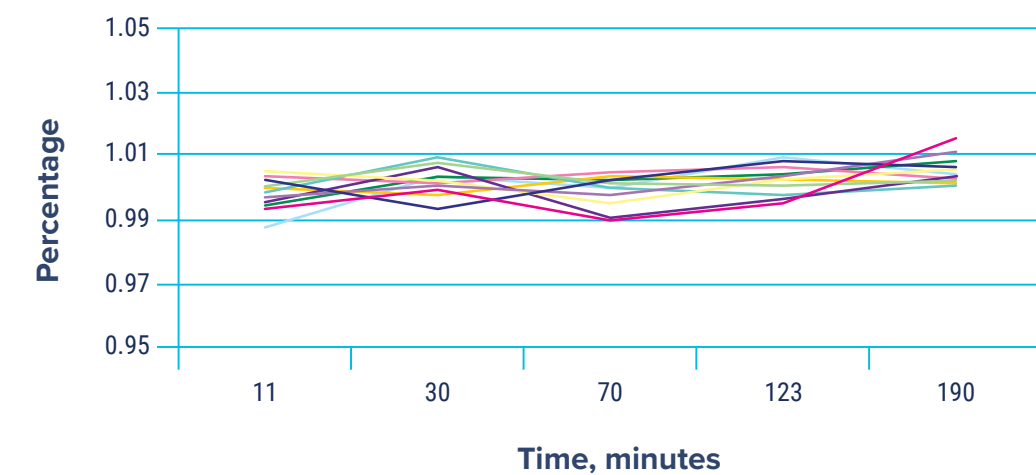
(1mL/min sample uptake)

Another benefit of the IsoMist XR results from the maintenance of a constant temperature, neither cooling nor heating. The data shown here was taken on an ICP-OES at 1mL/min sample uptake rate. Without temperature control, the intensity drifts as much as 3% high and 5% low during four hours of running (a range of 8%). With the IsoMist controlling and maintaining temperature at 21°C, intensities are held to within plus or minus 1%. This kind of stability is necessary to achieve maximum accuracy and reproducibility. Also, if drift is more severe, it will result in out-of-spec controls, necessitating re-running of standards and samples. Indeed, any ICP experiment reported in the literature should state the temperature of the spray chamber so that it is capable of being reproduced.

Without IsoMist XR



With IsoMist XR



[Spray Chamber Types](#) ✓

Glass Spray Chambers

Inert Spray Chambers

DC High Efficiency Spray Chambers

HydraMist

Single-Cell Sample Introduction System

[IsoMist XR](#)

Peltier Cooled Cyclonic Spray Chamber

IsoMist-MS

Helix CT ➤

Spray Chamber Selection Guide ➤

Stability Summary

The benefits of this added layer of stability are significant. Oftentimes, operators wait up to an hour or more for the instrument to reach equilibrium before starting the run; this is no longer necessary. Even after an uncontrolled instrument reaches equilibrium, the heating/ cooling system of the laboratory causes a sinusoidal temperature pattern which would be mirrored in the analytical results. The bottom line for environmental service labs and others is passing QC checks to avoid rerunning samples. If the prospect of rerunning is diminished, the laboratory will be more profitable.

- No need to wait 60 minutes for stabilization after start-up
- Eliminates the need for expensive lab temperature regulation
- Increases the likelihood of passing QC checks
- Eliminates rerunning of samples

IsoMist XR Target Markets

Some of the industries for whom a temperature-controlled spray chamber would have the most value are listed here. Any laboratory that needs to analyze volatile solvents would benefit from the cooling capability of the IsoMist. One interesting application is heating the spray chamber to reduce the viscosity of samples such as used engine oils and edible oils. In the precious metal business, the highest accuracy is desired. By eliminating or minimizing drift between calibrations, higher accuracy (and hence higher profitability) can be achieved.

- Oil refineries – light naphthas
- Solvent manufacturers – ketones & alcohols
- Environmental labs – eliminate calibrations
- Wear metals in used engine oils – reduce viscosity
- Precious metal refiners – greater accuracy
- Elan®/NexION® ICP-MS users – oxide reduction
- Regional hospital laboratories – small volumes
- Any “hot” determinations – reduced waste

[Spray Chamber Types](#)



[Glass Spray Chambers](#)

[Inert Spray Chambers](#)

[DC High Efficiency Spray Chambers](#)

[HydraMist](#)

[Single-Cell Sample Introduction System](#)

[IsoMist XR](#)

[Peltier Cooled Cyclonic Spray Chamber](#)

[IsoMist-MS](#)

[Helix CT](#)



[Spray Chamber Selection Guide](#)



Peltier Cooled Cyclonic Spray Chamber for Agilent® ICP-MS

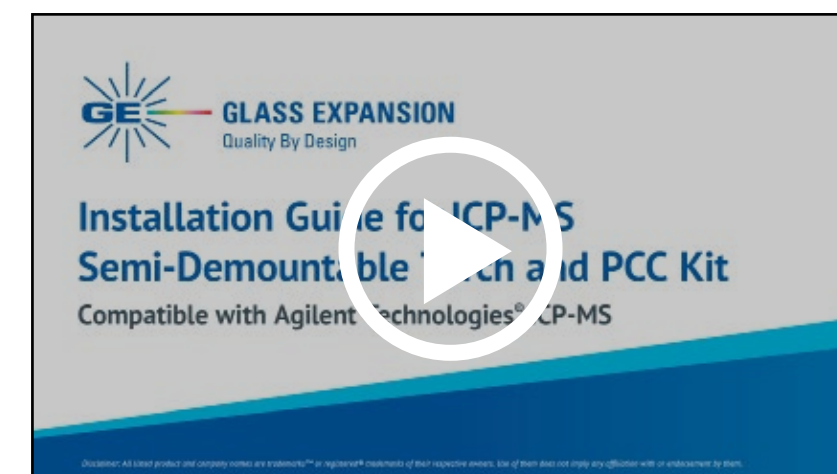
When the best temperature flexibility or temperature stability is required, we recommend the IsoMist Programmable Temperature Spray Chamber.

However, for many ICP-MS applications, a fixed temperature of around 2°C is used and no flexibility is needed. For these applications, we recommend the Peltier Cooled Cyclonic Spray Chambers for the Agilent® 7700/7800/7900/8800/8900 ICP-MS models. These accessories are based on the spray chamber and Peltier system of the IsoMist but are coupled to the electronics and water cooling systems of the ICP-MS.

Agilent® 7700/7800/7900/8800/8900 users can therefore get the benefit of a cyclonic spray chamber at an economical price. Compared to the Scott style spray chamber, the cyclonic spray chamber provides faster washout and increased sample throughput.

- Interchangeable glass, quartz, and PFA cyclonic spray chambers
- Faster washout than standard Scott-style spray chamber
- Higher sample throughput than standard Scott style spray chamber
- Temperature controlled from ICP-MS software and electronics
- Uses standard water cooling from ICP-MS unit
- Peltier cooling system
- Supplied with convenient mounting bracket

[More Information](#)



ICP-MS Semi-demountable Torch and PPC Kit Video Installation Guide

Spray Chambers

[Spray Chamber Types](#)

Glass Spray Chambers

Inert Spray Chambers

DC High Efficiency Spray Chambers

HydraMist

Single-Cell Sample Introduction System

IsoMist XR

Peltier Cooled Cyclonic Spray Chamber

[IsoMist-MS](#)

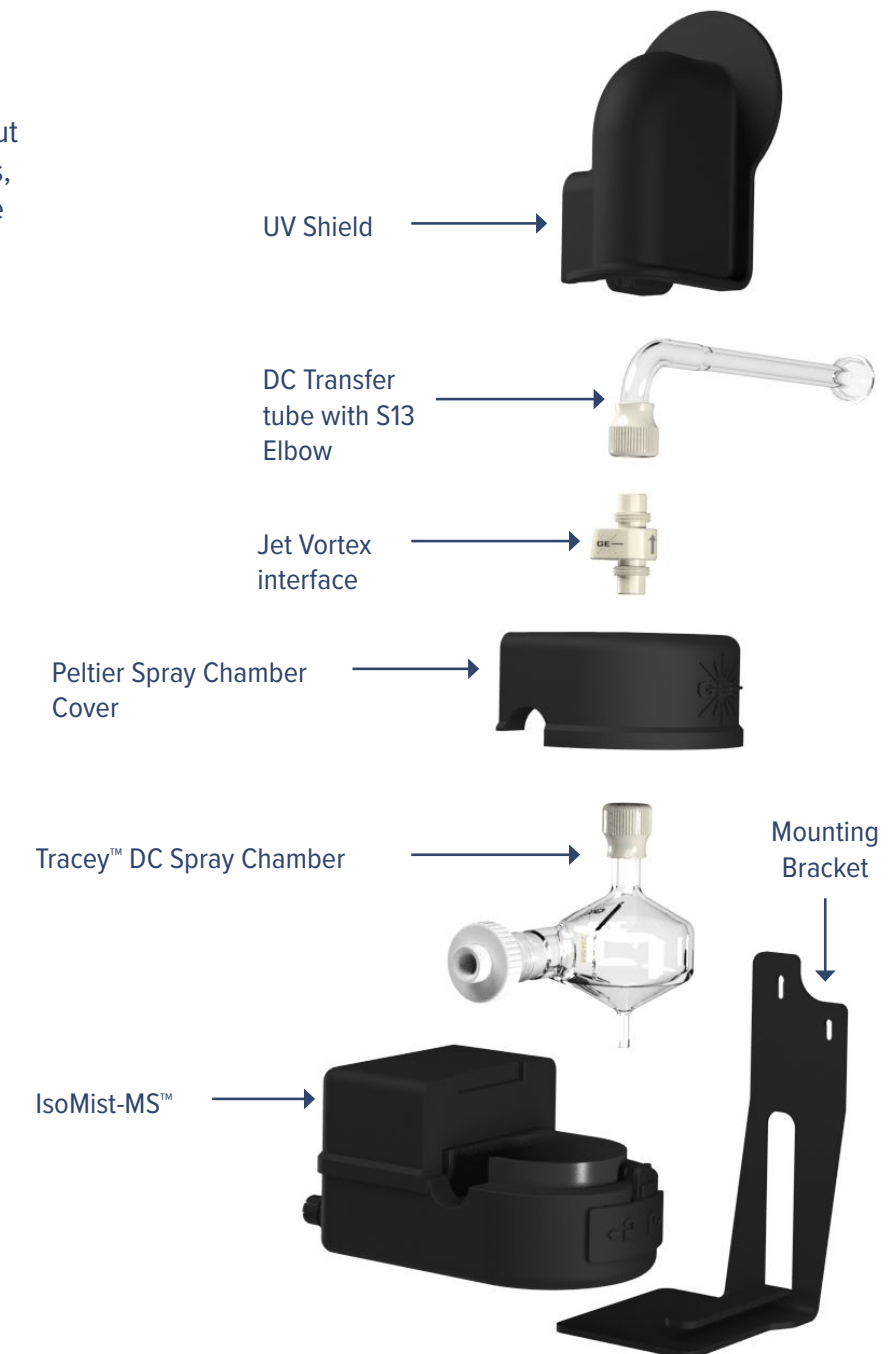
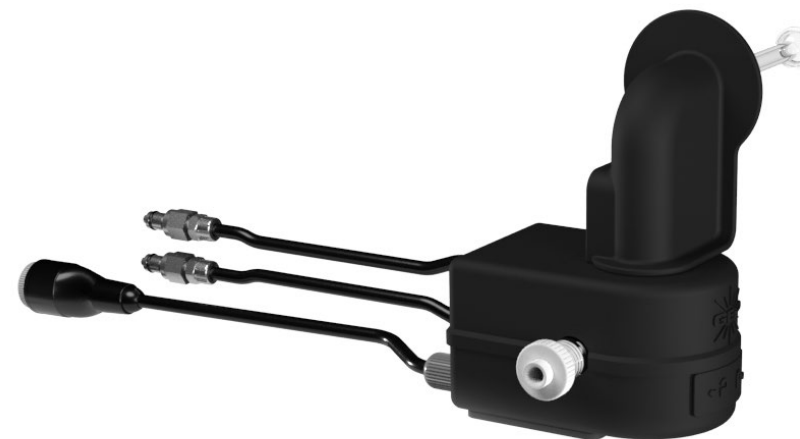
[Helix CT](#)

[Spray Chamber Selection Guide](#)

Glass Expansion IsoMist-MS™

The IsoMist-MS is a compact and lightweight design that has improved transport and washout efficiency for ICP-MS. Having interchangeable Tracey™ DC Spray Chambers available in Glass, PEEK, PFA or Quartz, the IsoMist-MS can handle any ICP-MS application. Compatible with the Agilent® 7850/7900/8900 and Thermo® Q/RQ/TQ ICP-MS.

- Next Generation IsoMist-Compact.
- DC (Direct Connection) Spray chamber.
- Low volume (30mL) cyclonic spray chamber for faster washout with Helix CT technology.
- Interchangeable Tracey™ DC spray chambers (Glass, PEEK, PFA & Quartz).
- Compatible with UHMI or HMI conditions.
- Light weight design.
- Improved transport efficiency with reduced sample path length.
- Suitable for Agilent® ICP-MS 7850/7900/8900 and Thermo® Q/RQ/TQ ICP-MS.



Spray Chambers

[Spray Chamber Types](#)



Glass Spray Chambers

Inert Spray Chambers

DC High Efficiency Spray Chambers

HydraMist

Single-Cell Sample Introduction System

IsoMist XR

Peltier Cooled Cyclonic Spray Chamber

[IsoMist-MS](#)

Helix CT



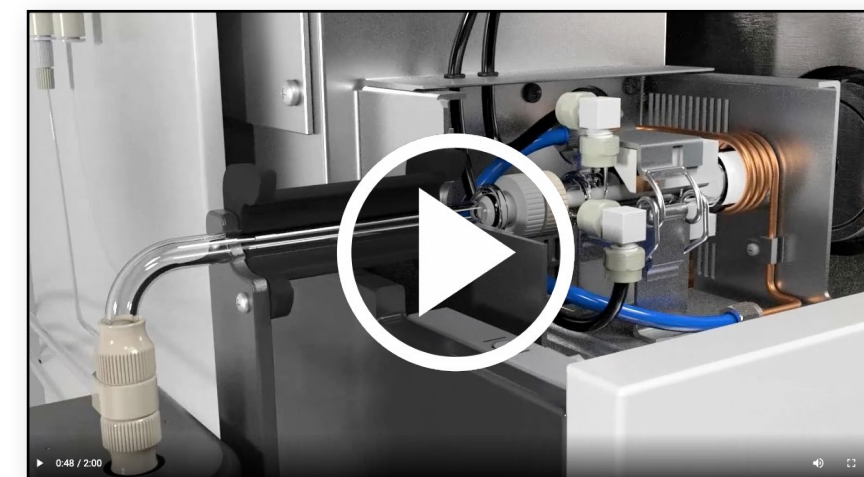
[Spray Chamber Selection Guide](#)



Jet Vortex Interface (JVI™) - Aerosol Filtration

The novel design (Patent Pending) JVI, adds a highly efficient Aerosol Filtration accessory to the IsoMist-MS, working in conjunction with the existing auxiliary gas options of the Agilent® and Thermo® ICP-MS. The JVI accessory allows the analyst to optimally fine-tune their instrument parameters, easily achieving oxide ratios well below 1% and minimizing deposition on the interface cones. A must have accessory for analyzing “real world” high-matrix samples.

- Reduces average particle size by 3-4% for every 0.05 L/min flow of JVI.
- Chemically inert, made from PEEK.
- Secure connection to gas supply, torch & DC spray chamber.
- Improved life of torch & interface cones.
- Reduce build-up on injector & interface cones.
- More robust plasma conditions.
- Improved long-term stability



IsoMist-MS Video: Agilent® 7850/7900/8900 ICP-MS



IsoMist-MS Video: Thermo® Q/RQ/TQ ICP-MS

Spray Chambers

Spray Chamber Types >

[Helix CT](#) >

Spray Chamber Selection Guide >

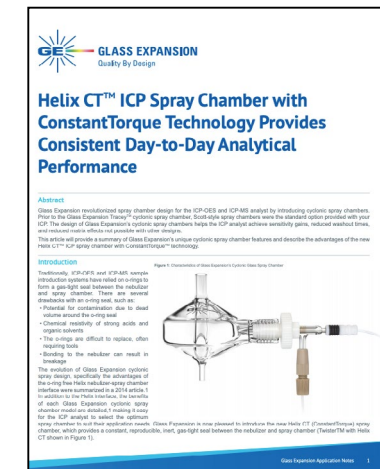
Exclusive Helix CT interface between nebulizer and spray chamber

The Helix CT locking screw with built-in torque control mechanism allows for a consistent seal of the PTFE ferrule against the nebulizer- making it impossible to overtighten or under tighten while ensuring a gas-tight seal every time. No need to worry about changing o-rings or nebulizers getting bonded to o-rings. The photo directly left shows an old-style spray chamber with o-rings. This spray chamber was sent to us by a customer who broke the nebulizer when trying to remove it after it bonded to the o-rings.

- Helix CT locking screw with ConstanTorque technology
- PTFE ferrule seals spray chamber
- Solution contacts only PTFE and glass
- Standard for all spray chambers
- Prevents pooling at nebulizer port reducing carryover

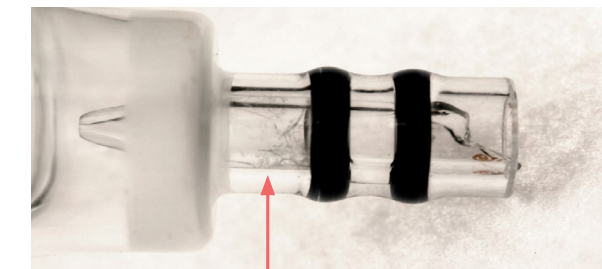
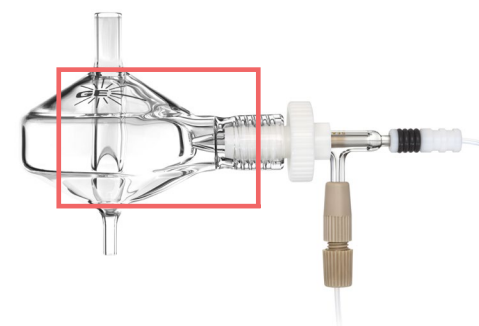
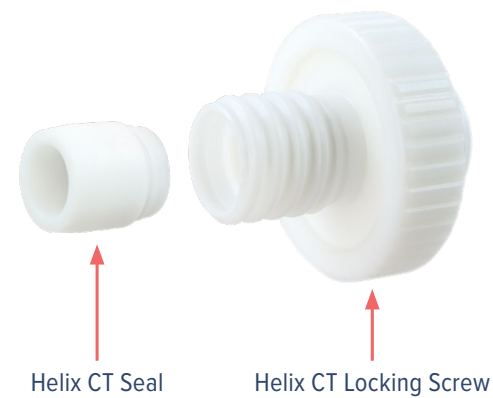


Helix CT Flyer



Helix CT Application Note

[More Information >](#)



[Return to Contents Page](#)

Spray Chambers

Introduction

Nebulizers

Spray Chambers

Torches

RF Coils

Cones

Accessories

Fittings & Connectors

Summary

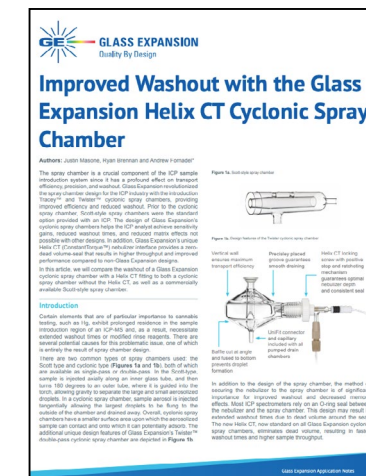
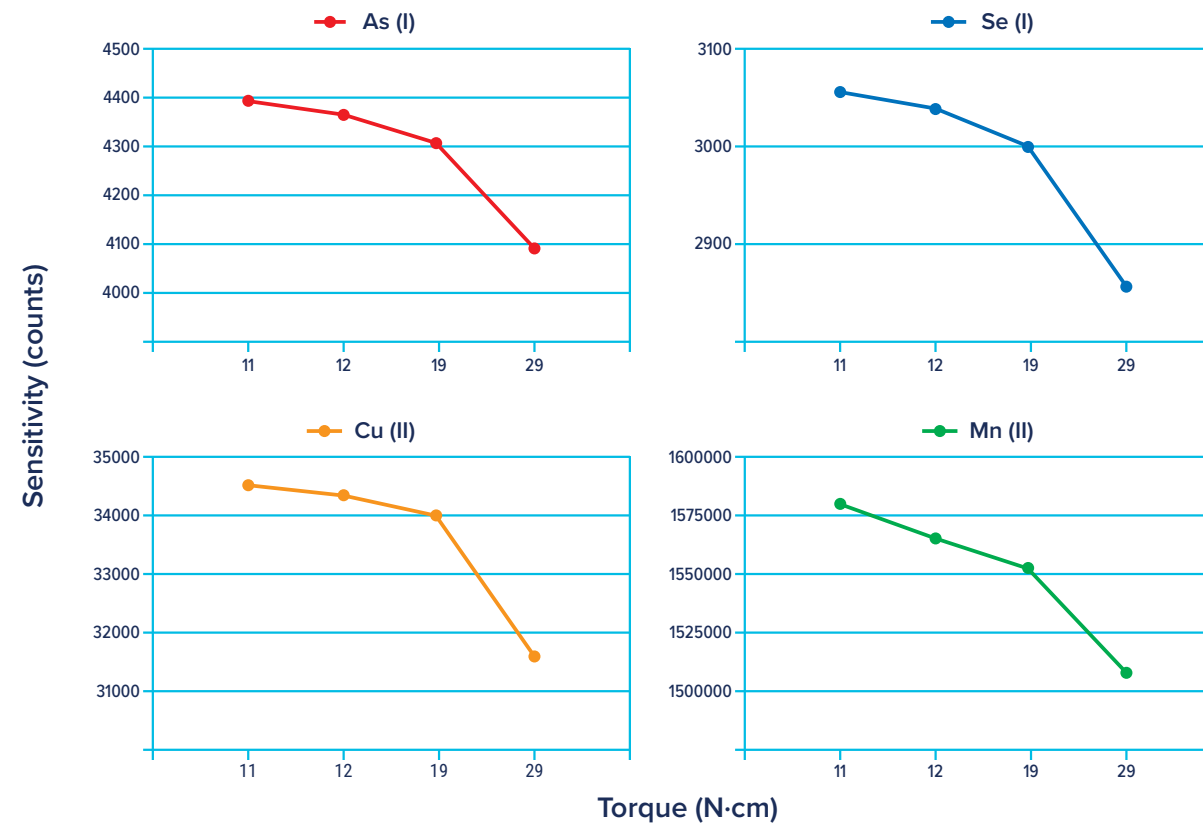
Spray Chamber Types >

[Helix CT](#) >

Spray Chamber Selection Guide >

Optimum Depth and Torque

The Helix CT interface still maintains the original positive stop to ensure that the nebulizer is inserted to the correct and optimum depth within the spray chamber. However, the torque applied to the nebulizer seal is also critical. Consistent nebulizer depth combined with ConstantTorque control provides the ICP analyst with unparalleled, reproducible day-to-day analytical performance.



Improved Washout with the Helix CT Cyclonic Spray Chamber

< [Return to Contents Page](#)

Spray Chambers

Spray Chamber Types >

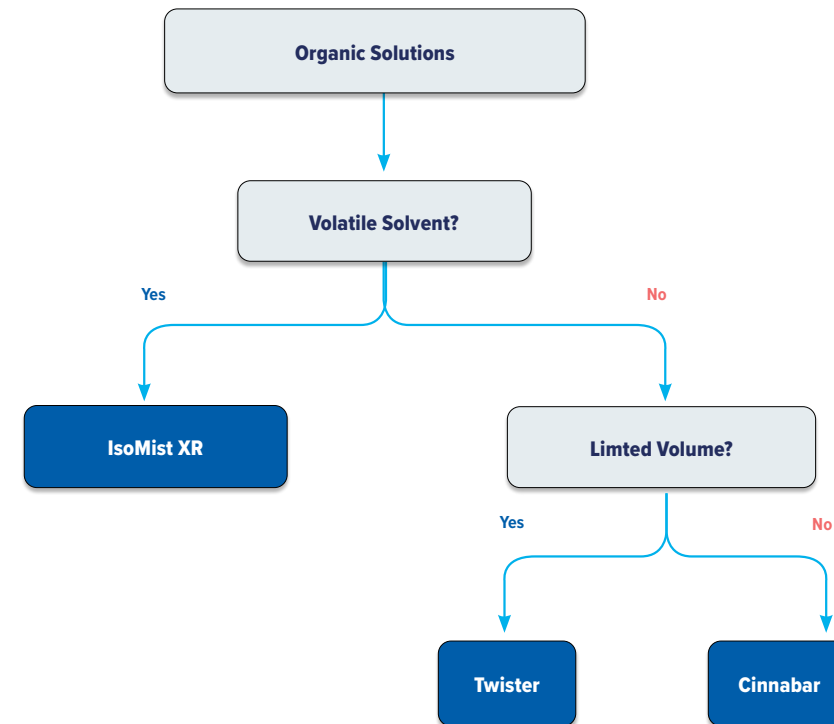
Helix CT >

[Spray Chamber Selection Guide](#) >

Spray Chamber Selection Guide

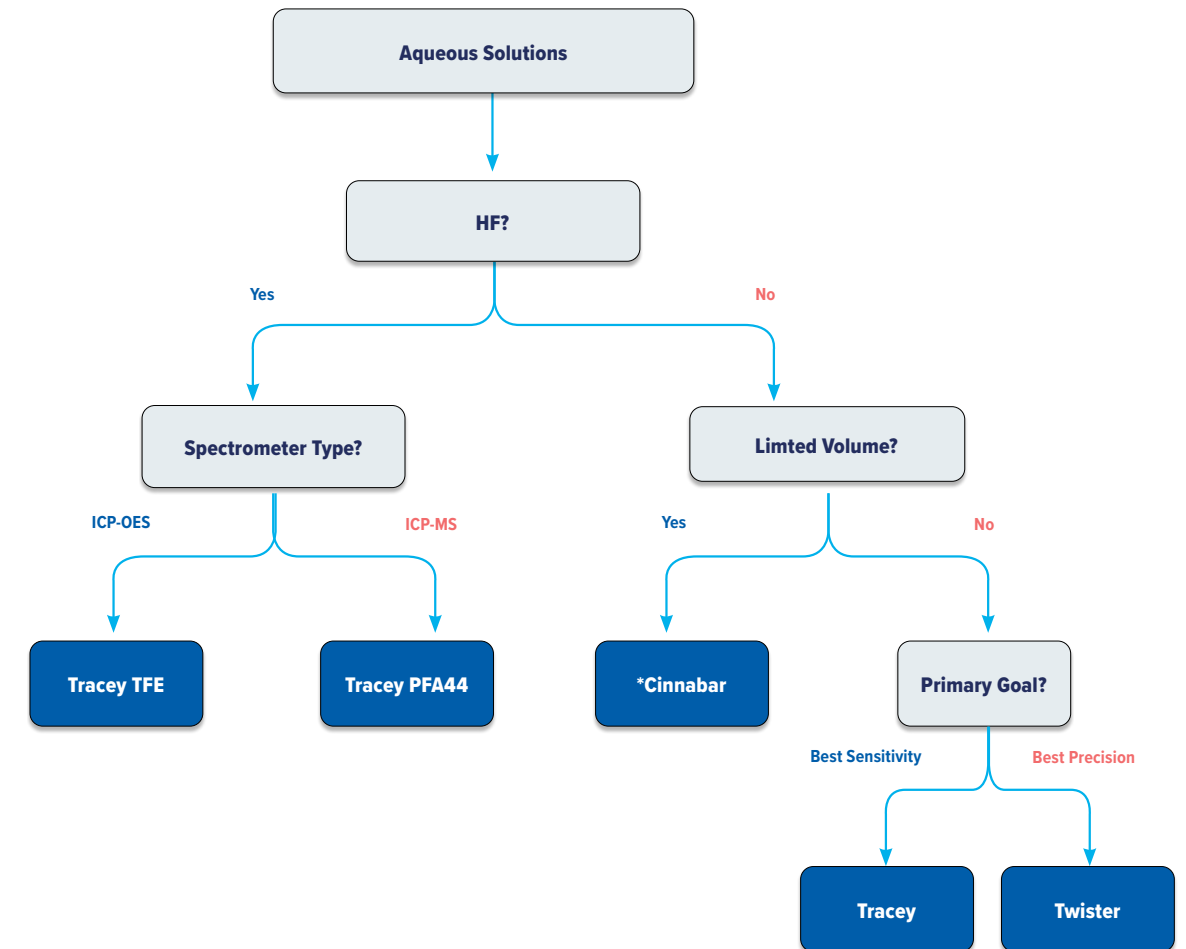
(Organics)

This guide summarizes the proper selection of a spray chamber based on the type of organic solvent analyzed.



(Aqueous)

Similarly, this guide walks the analyst through a series of questions leading to the proper spray chamber for a variety of aqueous sample types. *The Cinnabar Spray Chamber also provides a faster washout.



[Return to Contents Page](#)

[Torch Designs](#)[Torch Availability](#)[D-Torch](#)

Torch Designs

Glass Expansion offers a choice of torch design with varying degrees of demountability.

Single-piece quartz torch

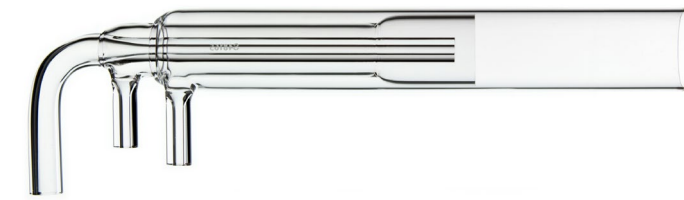
- No removable parts

Semi-demountable (SDT) torch

- Removable injector

D-Torch

- Removable injector
- Removable outer tube



Torch Designs >

[Torch Availability](#) >

D-Torch >

Torch Availability

This table illustrates which torch types are available for the individual instrument makes.

Element/Isotope	Single piece	SDT	FDT	D-Torch
Agilent Technologies® ICP-MS	✓	✓		✓
Agilent® (Varian) ICP-OES	✓	✓	✓	✓
Analytik Jena® ICP-OES	✓		✓	
Horiba®				✓
Leeman (Teledyne™)	✓	✓		
Nu/Micromass™	✓			✓
PerkinElmer® Elan		✓		✓
PerkinElmer® NexION		✓		✓
PerkinElmer® Optima		✓		✓
PerkinElmer® Avio				✓
Shimadzu®	✓	✓		
Hitachi®	✓	✓		
Spectro™	✓	✓		✓
Thermo Fisher Scientific® ICP-OES		✓		✓
Thermo Fisher Scientific® ICP-MS	✓	✓		

Torch Designs >

Torch Availability >

D-Torch ✓

[About](#)

Effects of Salt on Torches

Benefits of a Ceramic Torch

D-Torch DL Comparisons

Fully Ceramic D-Torch

D-Torch

This design is much less expensive than the ABC torches but still provides the major benefit of a demountable outer tube. For these torches, a ceramic inner tube is used for long life.

The outer tube takes the brunt of the punishment from both the sample and the plasma and is therefore the first part to deteriorate. A process called devitrification occurs from the exposure of quartz to salts at high temperature. The D-Torch is a cost-effective alternative for any laboratory with a moderate workload. They will only need to replace the outer tube when it wears, instead of replacing the entire torch. Customers will realize a saving after only a few replacements of the outer tube.

The demountable injector makes it easy to modify the torch to suit the analysis of HF-containing samples or organic solvents which typically require an injector with a smaller orifice.

The ceramic outer tube provides a greatly extended lifetime for demanding samples such as oils, fusions, or high-salt solutions.

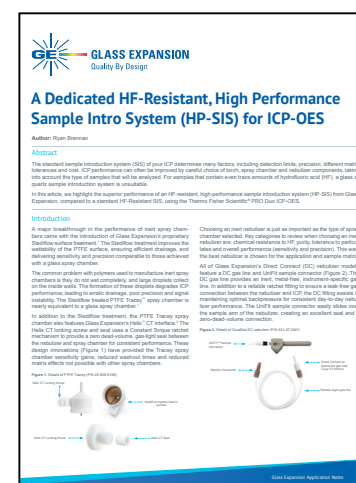


For NexION® 1000/2000/5000



For Thermo® PRO Duo

[More Information >](#)



A Dedicated HF-Resistant, High-Performance Sample Introduction System (HP-SIS) for ICP-OES

Torch Designs >

Torch Availability >

D-Torch ✓

[About](#)

Effects of Salt on Torches

Benefits of a Ceramic Torch

D-Torch DL Comparisons

Fully Ceramic D-Torch

D-Torch

Benefits

- Replace just outer tube (fastest to degrade)
- Easy to switch injector from HF to aqueous to organics
- Optional ceramic outer tube
- Economical price

[More Information >](#)



Agilent® 5100/5110/5800/5900 D-Torch Flyer



D-Torch Installation Video for Agilent® 5100/5110/5800/5900



For PerkinElmer® Avio



For Agilent® 5100/5110/5800/5900

[Return to Contents Page](#)

[Torch Designs](#)[Torch Availability](#)[D-Torch](#)[About](#)[Effects of Salt on Torches](#)[Benefits of a Ceramic Torch](#)[D-Torch DL Comparisons](#)[Fully Ceramic D-Torch](#)

Effect of Salt on Torches

These are the effects of devitrification. The torch in the middle has worn right through the quartz outer tube. The torch on the right shows the salting-out that can occur on the injector.

The D-Torch reduces the cost of torch replacement since only the outer tube is replaced.

The Elegra Argon Humidifier reduces salt deposits.

The ceramic outer tube of the D-Torch is made from sialon, which is a ceramic material derived from silicon nitride. Sialon is one of the most durable and robust ceramic materials known and maintains its properties at high temperatures. A combination of high temperature and salt deposits causes a quartz torch to devitrify. Higher concentrations of salt in the samples lead to more rapid devitrification. By contrast, the ceramic outer tube of the D-Torch does not devitrify and is not affected by salt deposits. The quartz torch in Figure (b), was run for only 6 hours with samples containing 10% NaCl and is already badly degraded. The ceramic D-Torch in Figure (c) was run for the same period and with the same samples as the quartz torch but shows no degradation at all. In general, the ceramic outer tube has a much longer lifetime, greatly reducing interruptions and downtime due to torch failure. Sialon is also beneficial for low-level Si determinations, where quartz outer tubes can produce high background signals.

[More Information >](#)

A.



B.



C.



Quartz torch (B) and ceramic torch (C) exposed to 10% NaCl for 6 hours.

Torch Designs >

Torch Availability >

[D-Torch](#) ✓

About

Effects of Salt on Torches

[Benefits of a Ceramic Torch](#)

D-Torch DL Comparisons

Fully Ceramic D-Torch

The Benefits of a Ceramic Torch

In general, the ceramic outer tube has a much longer lifetime, greatly reducing interruptions and downtime due to torch failure.

The ceramic outer tube is of particular benefit for:

- The analysis of wear metals in engine oils, where quartz outer tubes often suffer from a short lifetime.
- Si determinations, where quartz outer tubes often produce high background signals.
- Fusion samples or samples with high levels of dissolved solids cause quartz tubes to devitrify.

Lithium borate fusion samples

The D-Torch ceramic outer tube in the photo below has been running lithium borate fusion samples for three years at 5-7 days per week and 20-22 hours per day.

This ceramic tube is showing clear signs of wear and tear but it has been running very demanding samples for approximately 20,000 hours. And at the time this photo was taken it was still operational. As a comparison, before the ceramic D-Torch was installed, a standard quartz torch was lasting only about 100 hours. So the ceramic torch has outlasted 200 standard quartz torches, **SAVING THE USER AT LEAST \$40,000.**

[More Information >](#)

A.



B.



Ceramic tube after 3 years of (A) use compared with new ceramic tube (B).



Quartz torches often crack upon cooling due to thermal shock when running organic solvents.

[Return to Contents Page](#)

Torch Designs >

Torch Availability >

D-Torch ✓

About

Effects of Salt on Torches

Benefits of a Ceramic Torch

D-Torch DL Comparisons

Fully Ceramic D-Torch

D-Torch DL Comparison

A comparison of detection limits between the radial EMT torch and the radial ceramic D-Torch using default parameters for the plasma and sample introduction settings with 10 second integration times.

Element (λ)	Detection Limit (µg/L)	
	Radial Quartz Torch	Radial Ceramic D-Torch
Al 167	1.6	1.1
Ba 455	0.07	0.12
Cu 324	0.88	0.62
K 766	25.5	11.7
Mg 279	0.05	0.05
Mn 257	0.36	0.25
Ni 221	1.6	1.3
P 177	5.1	5.0
Zn 213	0.23	0.28



D-Torch for Thermo Fisher Scientific® Radial ICP-OES

Torch Designs >

Torch Availability >

D-Torch ✓

About

Effects of Salt on Torches

Benefits of a Ceramic Torch

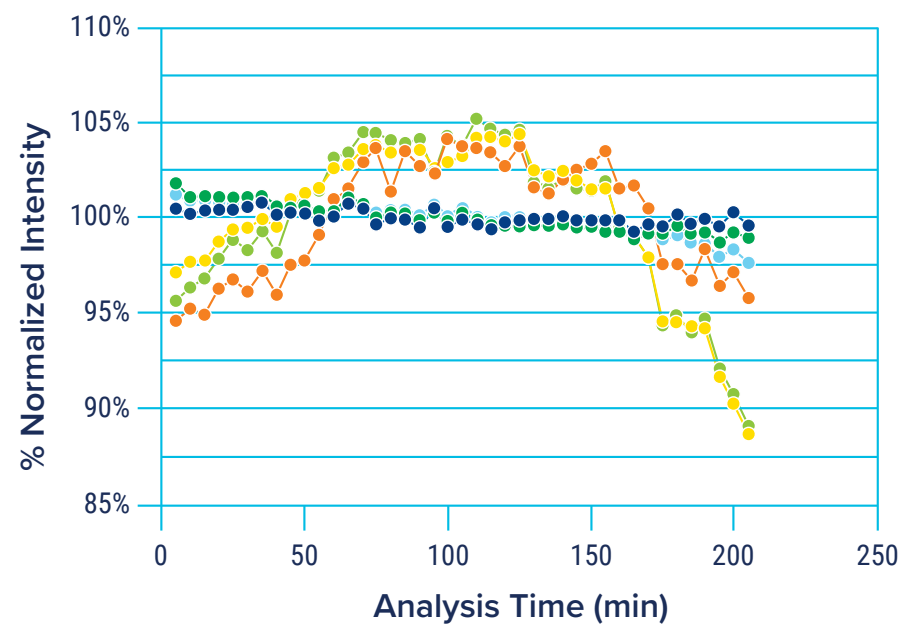
D-Torch DL Comparisons

Fully Ceramic D-Torch

Fully Ceramic D-Torch –Less Maintenance & Improved Stability with High TDS

The D-Torch incorporates a ceramic intermediate tube for greater robustness and provides the analyst with an outer tube (quartz or ceramic) that can be replaced when it fails rather than replacing the entire torch. A ceramic outer tube is of particular benefit for the analysis of difficult sample matrices such as high TDS and HF. The D-Torch also features an interchangeable injector, allowing the analyst to have a specific injector for each application whether aqueous, organics, high TDS, or HF. Having a demountable torch also allows for easy maintenance and cleaning.

The ceramic outer tube runs hotter than quartz which slows the build-up of material on the outer tube and results in a more robust plasma, a result which is especially important in the presence of high TDS samples.



● Zn 334.502nm 3.0% TDS D-Torch/Ceramic/HF Intro System ● Zn 334.502nm 2.2% TDS Semi-Demountable Torch/HF Intro System
● Ni 174.828nm 3.0% TDS D-Torch/Ceramic/HF Intro System ● Ni 174.828nm 2.2% TDS Semi-Demountable Torch/HF Intro System
● Pb 220.353nm 3.0% TDS D-Torch/Ceramic/HF Intro System ● Pb 220.353nm 2.2% TDS Semi-Demountable Torch/HF Intro System

< [Return to Contents Page](#)

[RF Coils](#)



Available RF Coils



RF Coils

A high quality RF coil is crucial to the smooth operation of an ICP spectrometer. Glass Expansion has developed a precise process for manufacturing coils for a wide variety of instrument models. Unlike other operators who take plated copper tubing and coil it, Glass Expansion coils the copper tubing first and then performs a consistent plating process of either gold or silver. A plastic former is inserted into the coil to guarantee and maintain the proper concentricity and spacing between turns. The former is also used in conjunction with the installation tool during the alignment process. The alignment tool kit includes a USB to walk you through the installation and alignment process. There is no reason to pay a service engineer to make a billable call (coils are considered consumables and are not covered under the instrument warranty).

Which Coil to recommend?

- Copper: labs on a tight budget
- Silver: most labs concerned with both long life and high performance
- Gold: highly corrosive environments
- Teflon-coated silver: longest lasting and best performance

Why Replace RF Coils?

- Regular replacement of corroded coils reduces the load on the RF generating system
- Changing corroded coils increases energy transfer, resulting in a more robust plasma and generally higher analytical line intensities
- Reduce chance of arcing

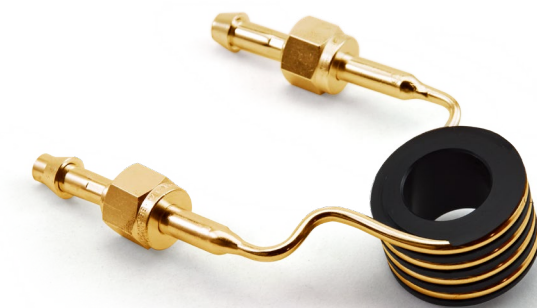
[More Information >](#)

Benefits:

- Plated after coiling
- Available in gold and silver
- Coil-former guarantees concentricity
- Coil-former maintains coil spacing
- Installation tool guarantees proper alignment
- Installation tool & USB eliminate need for a service call

When to Replace RF Coils?

- Coil surface appears corroded or pitted
- Torch outer tubes fail predominantly on one side
- Noticeable crackling noise during liquid aspiration
- More than two years old for ICP-OES
- More than 6 months old for ICP-MS



RF Coils

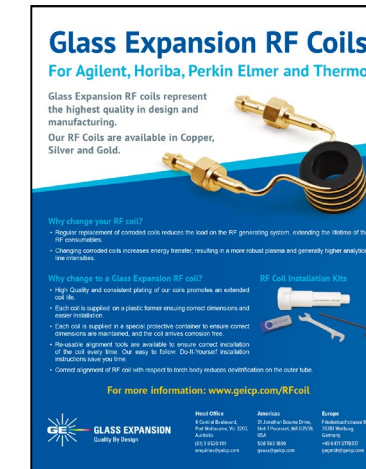
[Available RF Coils](#)



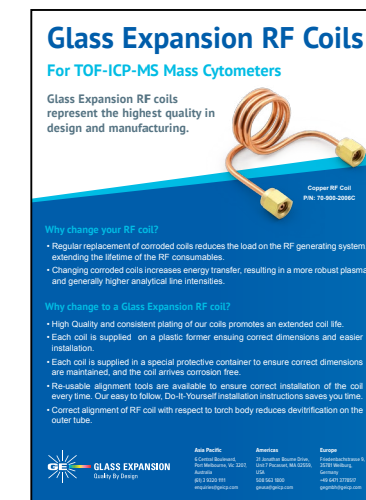
Available RF Coils

These are the coils currently available for the various instrument models. Please [inquire](#) if you do not see your specific ICP model listed.

Make	Model	Copper	Silver	Gold	Teflon Coated
Agilent Technologies®	7800/7900	✓	✓	✓	
	7700/8800	✓	✓	✓	
Agilent Technologies® (Varian)	5100/5110/5800/5900		✓	✓	
	700-ES		✓	✓	✓
Horiba®	ALL		✓	✓	
PerkinElmer® NexION	300/350	✓	✓		
PerkinElmer® Elan	6000/9000/DRC	✓	✓		
PerkinElmer® Optima	2000/4000/5000/7000		✓	✓	
Thermo Fisher Scientific®	6000/7000 MKII		✓	✓	✓
	6000		✓	✓	✓
Standard BioTools™ (Fluidigm)	TOF-ICP-MS	✓			



RF Coil Flyer



RF Coils for TOF-ICP-MS Mass Cytometers Flyer

[Return to Contents Page](#)

[Interface Cones for ICP-MS](#) >

ConeGuard™ Thread Protector >

Magnifier Inspection Tool >

Interface Cones for ICP-MS

Glass Expansion manufactures interface cones in its Melbourne facility. Our manufacturing plant includes several CNC machines and an electron beam welder and is the best equipped and best qualified cone machining plant in the world.

- Meet or exceed OEM specifications
- Available for all common ICP-MS models
- Satisfaction guaranteed

[More Information >](#)



Cone Availability

This table shows the various materials available for cone pairs (sampler and skimmer) for the different ICP-MS models.

ICP-MS	Ni	Al	Pt	Pt - Boron Free	Cu
Agilent®	✓	✓	✓	✓	
Standard BioTools® (TOF-ICP-MS)	✓				
Nu Instruments™	✓		✓		
PerkinElmer®	✓	✓	✓	✓	
Thermo® Finnigan	✓	✓	✓	✓	
Thermo® VG	✓	✓	✓		
Shimadzu®	✓		✓		✓



ICP-MS Cones Resource Guide



Interface Cones for TOF-ICP-MS Mass Cytometers Flyer

[Interface Cones for ICP-MS](#) >

[ConeGuard™ Thread Protector](#) >

[Magnifier Inspection Tool](#) >

Refurbishment of Platinum Cones

Extend the life of your platinum cones with our refurbishment program. Platinum cones have a much longer life than nickel cones but they do deteriorate over time. In many cases, a platinum cone can be refurbished multiple times and its lifetime greatly extended. As a customer service, Glass Expansion offers refurbishment of the platinum cones that we sell for the life of the cone.

- Fast turnaround
- Simple return processing

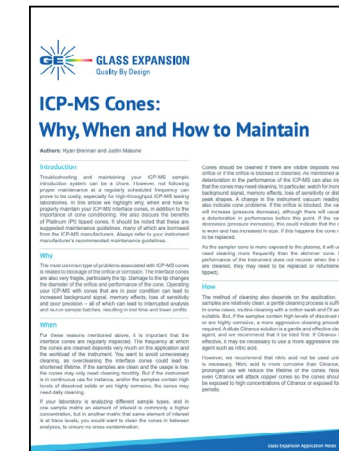
ConeGuard™ Thread Protector

When cleaning cones that have a screw thread, it is important that the thread is not contacted by any corrosive solution. If the thread gets corroded, the cone may not seal correctly or it may bond to the base and be difficult to remove. With Pt cones, the thread is likely to wear out before the Pt insert.

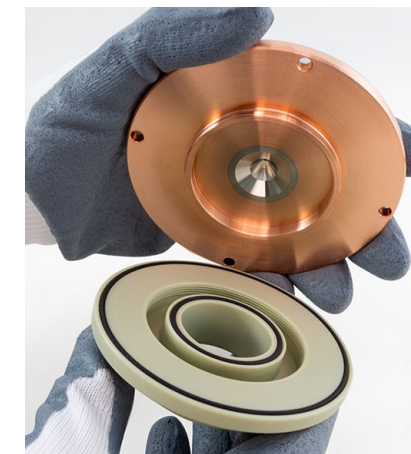
- Extend the life of your ICP-MS cones
- Seals the thread and protects it from corrosion during the cleaning process
- Keeps the thread in good condition to prevent the possibility of cross-threading and potential damage to the instrument housing

Simple to use

The ConeGuard simply screws onto the threaded part of the cone and o-ring seals prevent any solution from coming in contact with the thread.



ICP-MS Cones: Why, When and How to Maintain



ConeGuard with sampler cone for Agilent® 7500

Interface Cones for ICP-MS >

ConeGuard™ Thread Protector >

[Magnifier Inspection Tool](#) >

Magnifier Inspection Tool with Built-in LED Illumination

It is good practice to regularly inspect for wear and tear in your nebulizer tip, capillary tubing, and ICP-MS interface cones. This critical process can now be completed in-house and confidently with the Glass Expansion Magnifier Inspection Tool.

- 10X Magnification
- 8 LED Lights
- Manual Focus Knob
- 20mm Glass Reticle Horizontal Scale
- Protective storage Pouch

[More Information >](#)



Magnifier Inspection Tool P/N: 70-803-1923



Magnifier Inspection Tool Flyer

[Return to Contents Page](#)

[Elegra Argon Humidifier](#) ✓

[About](#)

Types

Analysis

Trident CT Kit >

Trident In-line Kit for HF >

Pump Tubing >

TruFlo Sample Uptake Monitor >

Guardian In-Line Filters >

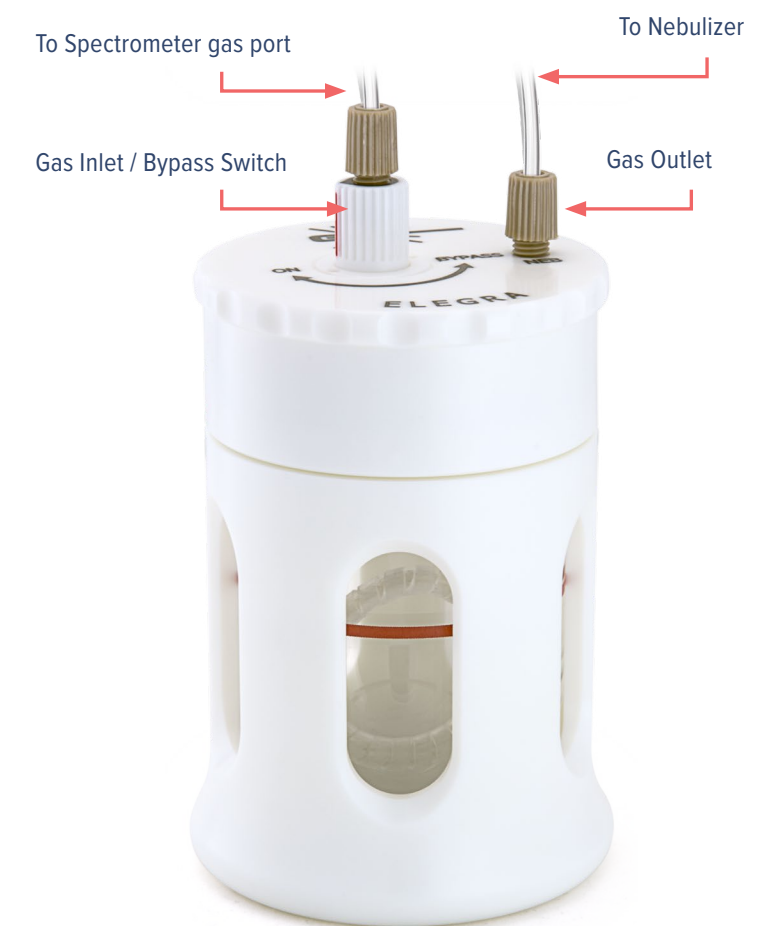
Guardian Autosampler Probe >

Sample Introduction Kits >

Maximizing Up-Time – Elegra Argon Humidifier

- Compact, cost-effective design.
- No heating or electric power is required.
- Non-pressurized water reservoir.
- An easy-to-use bypass switch allows you to take the Elegra off-line without disconnecting argon lines. (Not available with Elegra Dual)
- Highly efficient membrane humidification technology.
- Improved signal stability for samples with high TDS.
- Simple to use and maintain.
- Facilitates long, uninterrupted run times.
- Inert metal-free construction eliminates the possibility of contamination.
- Rugged and durable polymer casing.
- Maximum and minimum fill marks ensure that you are always operating under optimum conditions.
- Compatible with all ICP-OES and ICP-MS models. Direct connection to argon outlet provided for most models.
- Two-channel configuration is available for ICP-MS instruments using auxiliary argon.

[More Information >](#)



Accessories

Elegra Argon Humidifier

About

Types

Analysis

Trident CT Kit

Trident In-line Kit for HF

Pump Tubing

TruFlo Sample Uptake Monitor

Guardian In-Line Filters

Guardian Autosampler Probe

Sample Introduction Kits



Two Versions of the Elegra

The Elegra argon humidifier is a good way to reduce the salting-out we saw earlier at the injector tip. The Elegra is available in two models.

The standard Elegra Argon Humidifier comes with a bypass switch. Once the reservoir is filled and gas lines connected, the humidifier is in-line and can simply be switched ON or OFF by rotating the switch to start or stop humidification.

The Dual Elegra Argon Humidifier is for ICP-MS instruments using Auxiliary argon. In this system the second channel is used to humidify auxiliary/make-up gas to sample introduction system.



Elegra Humidifier

Elegra Dual Humidifier

Elegra Stand



P/N 70-803-1581
Elegra Mount for
Agilent® 7900 ICP-MS



Elegra Flyer



Spectroscopy Application
Notebook, February 2016, p10-11

[Return to Contents Page](#)

[Elegra Argon Humidifier](#) ✓

About

Types

[Analysis](#)

Trident CT Kit >

Trident In-line Kit for HF >

Pump Tubing >

TruFlo Sample Uptake Monitor >

Guardian In-Line Filters >

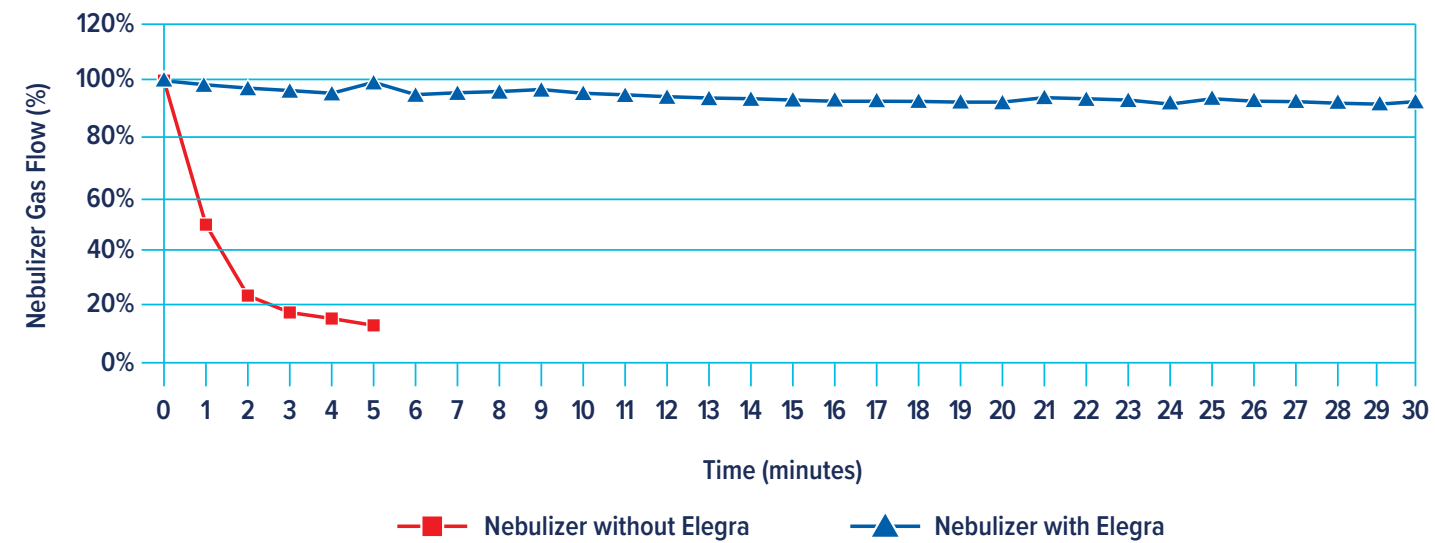
Guardian Autosampler Probe >

Sample Introduction Kits >

Analysis

The graph below is the result of an extreme test, aspirating a 25% salt solution continuously without rinsing. Without the Elegra, the nebulizer begins to clog after only a few minutes as designated by the steep decrease in nebulizer flow. However, with the Elegra installed, the nebulizer is stable for well over 30 minutes.

Elegra Nebulizer High TDS Stress Test (25% NaCl)



[Elegra Argon Humidifier](#) ✓

About

Types

[Analysis](#)

Trident CT Kit >

Trident In-line Kit for HF >

Pump Tubing >

TruFlo Sample Uptake Monitor >

Guardian In-Line Filters >

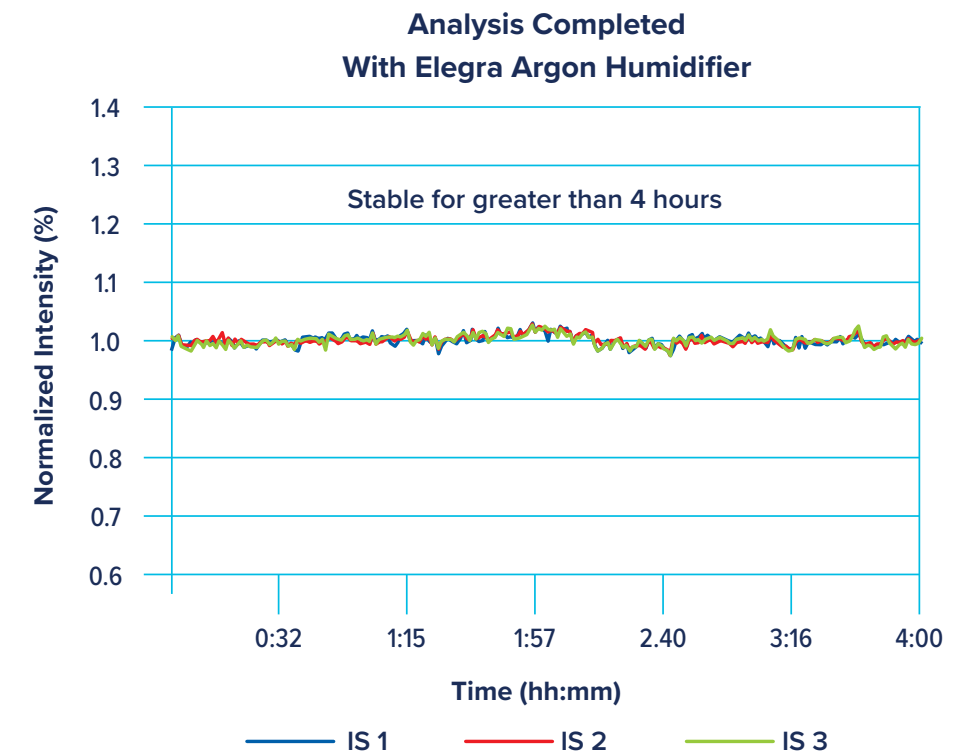
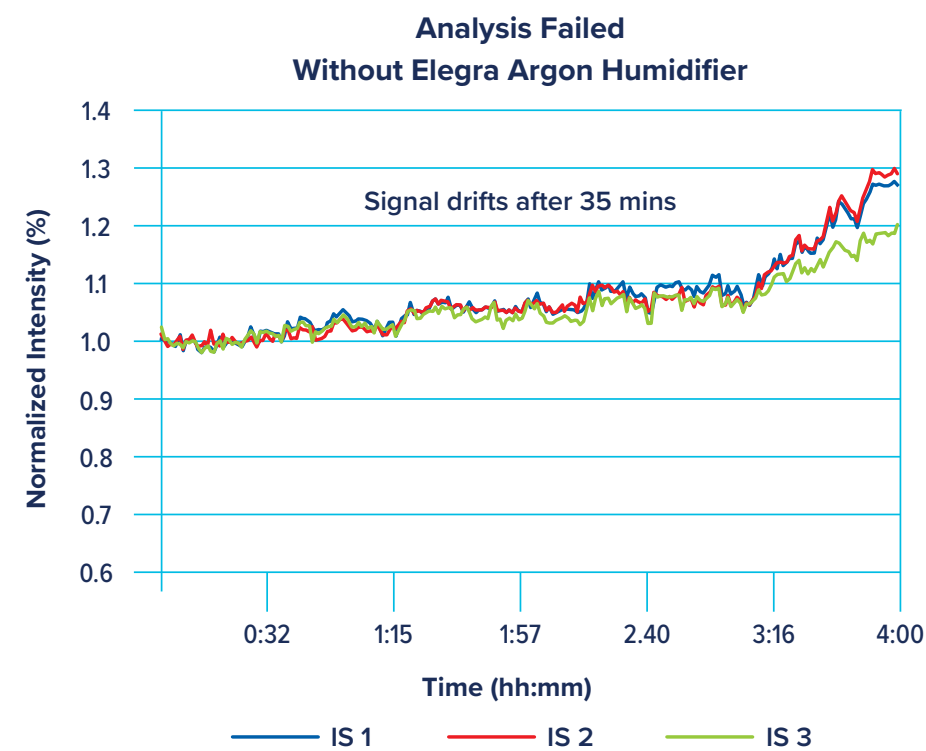
Guardian Autosampler Probe >

Sample Introduction Kits >

Analysis

The graphs below demonstrate the benefit of using the Elegra with the real-world application of analyzing fusion samples with 0.5% lithium metaborate by ICP-OES. All three internal standard lines monitored began to drift quickly when no Elegra was used, while their responses were very stable with the Elegra installed.

Internal Standard Signal for Three Lines - Stability in 0.5% Lithium Metaborate



- Elegra Argon Humidifier >
- [Trident CT Kit](#) >
- Trident In-line Kit for HF >
- Pump Tubing >
- TruFlo Sample Uptake Monitor >
- Guardian In-Line Filters >
- Guardian Autosampler Probe >
- Sample Introduction Kits >

Trident CT™ In-Line Reagent Additions Kit

Part Number	Description
60-703-1179	Trident CT In-Line Reagent Additions Kit

The Trident CT™ Mixing Tee is based on the industry proven design of the Trident, but with the addition of Glass Expansion's ConstantTorque™ (CT) technology to provide a simple to use, leak-free connection for both the internal standard and sample, every time.

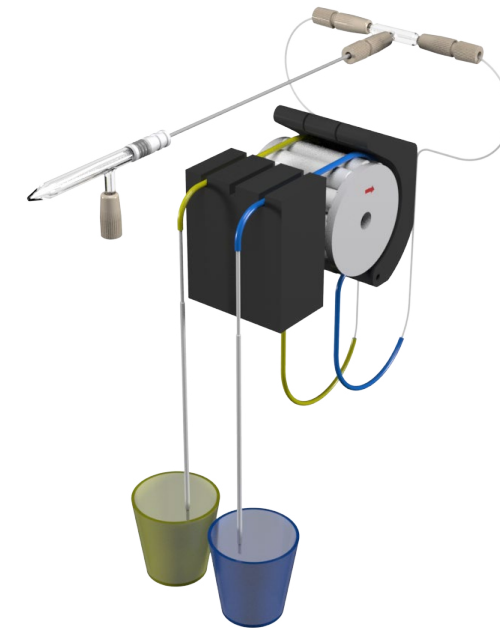
The heart of the kit is the mixing chamber, designed with zero dead volume ConstantTorque fittings. With other mixing chambers, worn or improperly fitted connections leak, inject a stream of air bubbles into the nebulizer flow which degrades short-term analytical precision (%RSD). By using ConstantTorque ratchet style fittings, the Trident CT eliminates air-leaks, optimizing analytical performance.

The Trident CT features:

- Ideal for all ICP-OES and ICP-MS systems
- Mixing tee guarantees intimate mixing with minimal washout time
- Totally modular
- Easy installation of Contour flared-end tubing

The Trident CT provides a simple, easy, and error-free way to continuously add internal standards or ionization buffers in ICP Spectrometry.

[More Information >](#)



Trident CT Mixing Chamber Glass with 1/4-28 Connectors



Trident CT Flyer



Trident CT Application Note

[Elegra Argon Humidifier](#) >[Trident CT Kit](#) >[Trident In-line Kit for HF](#) >[Pump Tubing](#) >[TruFlo Sample Uptake Monitor](#) >[Guardian In-Line Filters](#) >[Guardian Autosampler Probe](#) >[Sample Introduction Kits](#) >

Trident In-line Reagent Addition Kit for HF applications

Part Number	Description
60-808-1150	For HF applications

Manual sample dilution, when desired, or the addition of internal standard element(s) can be a tedious and error-prone process. The Trident kit allows you to automatically carry out these processes accurately and without extra labor. Two kits are available, one comprising a glass tee (Trident CT Kit) and another which includes an HF-resistant tee. An extra channel on the instrument peristaltic pump is required. The dilution factor is determined by the choice of pump tubing ID for the sample and diluent (internal standard).

The Trident kit can be used with all ICP-OES and ICP-MS instruments. The tee has a built-in mixing chamber that guarantees mixing of the sample and diluent yet requires minimal washout time between samples. The kit is modular so that each component can be replaced individually when needed. To facilitate the installation of small ID pump tubing to either minimize or maximize the dilution factor, we supply a complete line of Contour Flared-end Tubing.

- Ideal for all ICP-OES and ICP-MS systems
- Mixing tee guarantees intimate mixing with minimal washout time
- Totally modular
- Easy installation of Contour flared-end tubing

[More Information >](#)

Elegra Argon Humidifier >

Trident CT Kit >

Trident In-line Kit for HF >

Pump Tubing ✓

[Contour Flared-end Tubing](#)

Calculators

TruFlo Sample Uptake Monitor >

Guardian In-Line Filters >

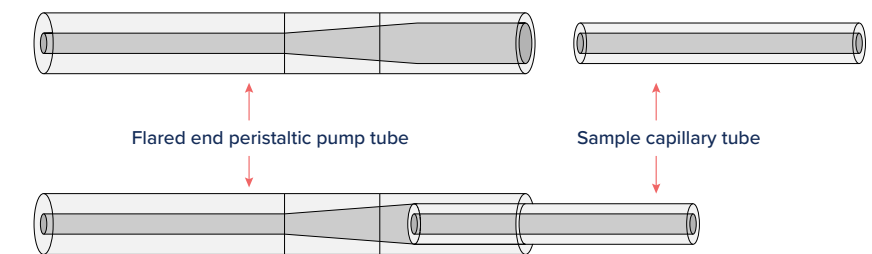
Guardian Autosampler Probe >

Sample Introduction Kits >

Contour™ Flared-end Tubing

The Contour line of flared-end tubing is available in standard PVC, Solva, Viton, and Tygon MH materials and from 0.13mm to 3.17mm ID. It makes it easy to minimize sample dilution when adding internal standards without worrying about the difficulty of installing small ID tubing.

- Flared at both ends
- Available in all materials and sizes
- Easy to minimize sample dilution when using internal standard



Pump tubing for all applications

If you are not sure what the best tubing is for a particular application, our technical support staff can provide a recommendation.

- PVC – for most routine applications using dilute acid solutions
- Solva – for hydrocarbons and petroleum products (eg. gasoline, kerosene)
- Viton – for concentrated acids and corrosive solvents
- Tygon MH – for organic solvents such as MIBK

Optimizing Tubing ID's

Some common examples of the setup for adding internal standard are listed here. These have all been selected to maintain proper pump speed and total liquid delivery to the nebulizer.

- Typical sample tube ID: 0.76 or 0.89mm ID
- Typical IS tube ID: 0.19 to 0.38mm ID
- Volume varies as (Radius)²
- Thermo: 0.89 and 0.38mm ID (20% Dilution)
- PE: 0.76 and 0.25mm ID (10% Dilution)
- Minimum dilution: 0.89 and 0.13mm ID (2% Dilution)

Elegra Argon Humidifier >

Trident CT Kit >

Trident In-line Kit for HF >

Pump Tubing ✓

Contour Flared-end Tubing

Calculators

TruFlo Sample Uptake Monitor >

Guardian In-Line Filters >

Guardian Autosampler Probe >

Sample Introduction Kits >

Trident Dilution Calculator

www.geicp.com

A Trident dilution calculator is available at our web site. Simply enter the selections for both the sample and internal standard tubing and the calculator tells you the dilution effect on both the sample and internal standard in terms of % and dilution factor.

Sample pump tubing ▼
Internal standard pump tubing ▼

Sample is diluted by **10.5%**
ie Final conc. of sample is **0.895** times initial concentration

Internal standard is diluted by **89.5%**
ie Final conc. of internal standard is **0.105** times initial concentration
or Internal standard is diluted by a factor of **9.5**

This calculation should be used as a guide only. Variations between pump tubes and roller pressures mean that the accuracy of the calculation cannot be guaranteed.

[More Information >](#)

Elegra Argon Humidifier >

Trident CT Kit >

Trident In-line Kit for HF >

Pump Tubing ✓

Contour Flared-end Tubing

Calculators

TruFlo Sample Uptake Monitor >

Guardian In-Line Filters >

Guardian Autosampler Probe >

Sample Introduction Kits >

Pump Speed and Sample Uptake Calculator

www.geicp.com

Some ICP software systems provide information on the pump speed required for a particular sample uptake but many do not. In this situation, the user often has no idea what the sample uptake is. The Calculator on our website enables the user to find out what pump speed is needed to give a specific uptake or, alternatively, what the uptake is for the pump speed being used.

- Choose the right pump tubing to give you the required sample uptake
- Select the pump speed to give you the required sample uptake
- Find out what the sample uptake is with the pump tubing and pump speed you are currently using

[More Information >](#)

Step 1. Select pump configuration

Choose ICP model ▾

Pump diameter (to outside of rollers) mm

Number of rollers

Roller diameter mm

Step 2. Select pump tubing

Select pump tubing ▾

Step 3. Calculate pump speed or sample uptake

Sample uptake (µl/min) Pump speed RPM

Enter your required sample uptake to calculate the pump speed OR your actual pump speed to calculate the sample uptake.

This calculation should be used as a guide only. Variations between pump tubes and roller pressures mean that the accuracy of the calculation cannot be guaranteed.

- Elegra Argon Humidifier >
- Trident CT Kit >
- Trident In-line Kit for HF >
- Pump Tubing >
- [TruFlo Sample Uptake Monitor](#) >
- Guardian In-Line Filters >
- Guardian Autosampler Probe >
- Sample Introduction Kits >

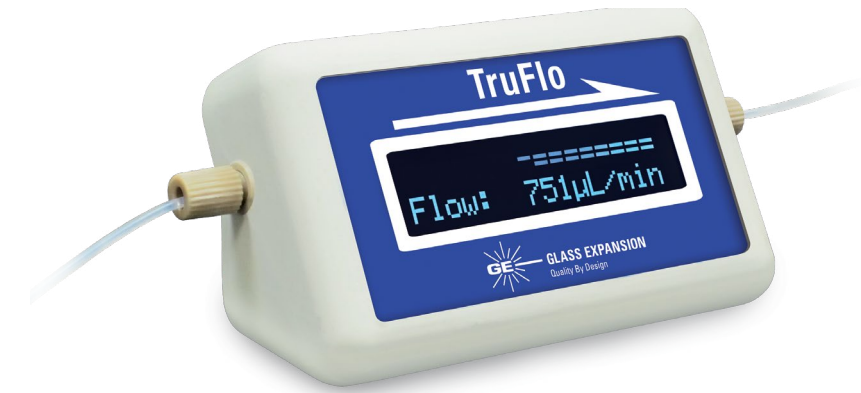
TruFlo Sample Uptake Monitor

- Worn pump tubing?
- Worn pump rollers?
- Improperly adjusted pump tension?
- Clogged nebulizer?
- Kinked sample capillary?

Our TruFlo sample uptake monitor addresses an issue that has been ignored until now. The sample uptake rate is a critical parameter, one that affects both the magnitude and precision of the analytical signal. The TruFlo allows you to monitor this parameter in real time, enabling you to diagnose problems like the ones shown here before the validity of your results is jeopardized. Its the perfect tool for Single Cell analysis method development.

It uses thermoelectric sensing to measure liquid flow. A few calories of heat are added upstream and the temperature change between two sensors is measured. The temperature change is related to liquid flow rate.

[More Information >](#)



TruFlo™ Sample Monitor

- Infallible diagnostic tool
- Continuous real-time flow measurement
- Reduces sample repeats
- Sounds out-of-range alarm
- Stores 24 hours of data
- Ideal for sample introduction by peristaltic pump or natural aspiration
- Suitable for all ICP-OES and ICP-MS models

Do you ever need to repeat the analysis of a sample due to:

- A blocked nebulizer?
- Worn peristaltic pump tubing?
- Increased pressure of the pump tubing clamp?

With the digital display of the TruFlo™ Sample Monitor, you always know the actual rate of sample uptake to your nebulizer. This enhances the day-to-day reproducibility of your results and reduces the need to repeat measurements due to a blocked nebulizer, worn pump tubing or incorrect clamping of the pump tube. And the backlit glass sample path ensures that there is no memory effect or sample contamination. The TruFlo can even record an alarm if the sample uptake is outside your specified limits.

The TruFlo is also ideal if you are relying on the natural aspiration of the nebulizer. Many operators, particularly of ECP-AES, use natural aspiration in order to minimize the effect of possible pump noise from their measurements. With the TruFlo, you always know what your sample uptake is and you can take immediate corrective action if there is any change.

The actual sample flow is shown on the TruFlo's about digital display and a graph of the flow versus time can also be displayed on your computer.

Part No.	Measurement Flow range (µL/min)	Calibration Flow range (µL/min)	Input vol. volume (µL)	Sample Path
19-801-043	0 - 4.0	0.2 - 4.0	0.10	Peristaltic pump + FPEX
19-801-070	0 - 1.0	0.05 - 1.0	0.05	Peristaltic pump + FPEX
19-801-074	0 - 0.05	0.001 - 0.05	0.005	Quartz + FPEX
19-801-080	0 - 0.05	0.02 - 0.05	0.10	HF nebulizer
19-801-081	0 - 1.0	0.05 - 1.0	0.05	HF nebulizer
19-801-082	0 - 0.05	0.001 - 0.05	0.005	HF nebulizer

The TruFlo is normally calibrated using deionized water. It is critical in identifying any change in sample flow with non-aqueous solutions, even though the absolute accuracy of the flow reading may be outside the specified design. The TruFlo can be calibrated to provide accurate flow readings with non-aqueous solutions if required.

For more information visit: www.gelgo.com

GLASS EXPANSION
Quality By Design

TruFlo Flyer

Cleaning and Handling The TruFlo™ Sample Monitor

The TruFlo sensor is a highly sensitive measurement device that should be properly cleaned to ensure high performance. Improper cleaning or an incorrectly installed nebulizer can affect the sensor's ability to measure sample uptake. The sensor is sensitive to cleaning after usage and before using the sensor for longer periods.

1. Explanation

Inside the TruFlo is a sensor that measures the flow through the wall of a thin-walled glass capillary. Because the measurement uses the heat propagation through the glass wall and the heat exchange with the medium, it is critical that the capillary of the flow with the medium is replaced. Periodic cleaning of the glass wall and roller is required to ensure the best results.

Because the capillary is so thin, it is not possible to clean the glass with a brush. Instead, the capillary should be cleaned using a cleaning solution. The TruFlo can be cleaned using a cleaning solution. A cleaning solution should be used to clean the capillary. The TruFlo can be cleaned using a cleaning solution. The TruFlo can be cleaned using a cleaning solution.

Light signs of deposits on the glass are measurement deviations over the whole flow range and/or effects of the measurement. The measurement deviations can be positive or negative.

GLASS EXPANSION
Quality By Design

Cleaning & Handling the TruFlo

Elegra Argon Humidifier >

Trident CT Kit >

Trident In-line Kit for HF >

Pump Tubing >

[TruFlo Sample Uptake Monitor](#) >

Guardian In-Line Filters >

Guardian Autosampler Probe >

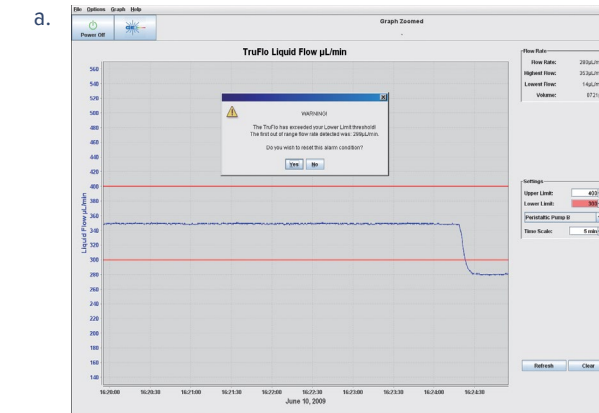
Sample Introduction Kits >

Features of TruFlo

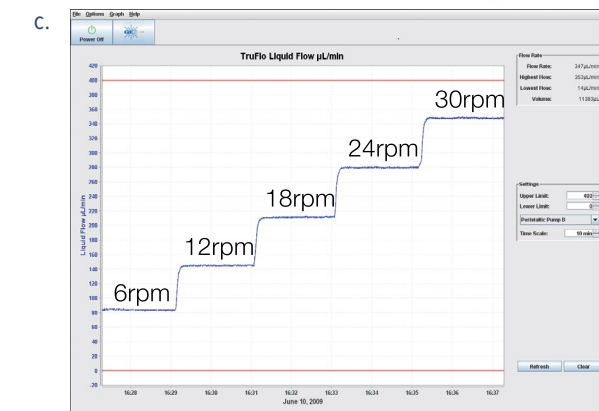
- Adjustable damping
- Settable alarm limits
- Digital display
- Recordable graph
- Range: 0 to 4mL/min
- HF resistant models available
- Can be calibrated for non-aqueous solutions

Graphic Benefits

- Graph a demonstrates the application of alarm limits. Once the flow rate falls outside the preset acceptable range, an audible and visible alarm occurs alerting the operator to a problem immediately.
- The graphic display facilitates tasks that are otherwise difficult. Graph b shows the effect of tightening the tension on the pump tubing half a turn at a time. Too little tension results in erratic flow and hence erratic results where too much tension unnecessarily wears the tubing and decreases tubing life. With the graphic display, the analyst is always certain that just the right pressure is applied.
- Graph c shows the effect of increasing pump speed on flow rate. There is no need to calculate the flow rate based on arcane formulas of tubing volume and pump speed or to use a graduated cylinder and a stopwatch. Just read the flow rate right off the display.



Adjusting pump tension



Uptake rate vs. pump speed

Elegra Argon Humidifier >

Trident CT Kit >

Trident In-line Kit for HF >

Pump Tubing >

TruFlo Sample Uptake Monitor >

Guardian In-Line Filters ✓

[Guardian In-Line Particle Filter](#)

Guardian DC In-Line Non-Return Gas Filter

Guardian Autosampler Probe >

Sample Introduction Kits >

Guardian In-Line Particle Filter

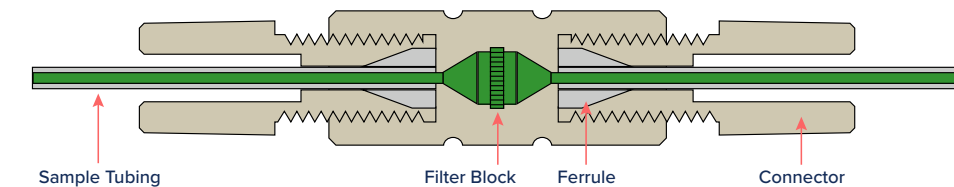
If there are particulates in your samples, there is a risk that they may get trapped in the fine channels of your sample line or within the nebulizer. The Guardian In-Line Particle Filter provides a simple and effective way to eliminate this risk. This particle filter is easily inserted in the sample tubing between the autosampler probe and the nebulizer. It increases the life span of high throughput valves and reduces their maintenance required. Compatible with 1.6mm and 1.3mm Sample tubing.

Benefits

- Reduces the chance of a blocked nebulizer
- Protects high throughput valves from damage from particulate matter.
- Enhances the day-to-day reproducibility of your results
- Purpose-built clog-resistant design
- Incorporates a 120 micron filter
- Available in 1/16 inch (1.6mm) and 1.3mm OD sample tubing
- Filter and Housing Material: HF Resistant PEEK
- Particle build-up is easily removed by back-flushing and ultrasonic cleaning

Back Flushing

Can be conveniently done using an adaptor connected to the Eluo Nebulizer Cleaning Tool.



Close plunger →

→ To flush Inline Particle Filter

Elegra Argon Humidifier >

Trident CT Kit >

Trident In-line Kit for HF >

Pump Tubing >

TruFlo Sample Uptake Monitor >

Guardian In-Line Filters ✓

Guardian In-Line Particle Filter

Guardian DC In-Line Non-Return Gas Filter

Guardian Autosampler Probe >

Sample Introduction Kits >

Guardian DC In-Line Non-Return Gas Filter

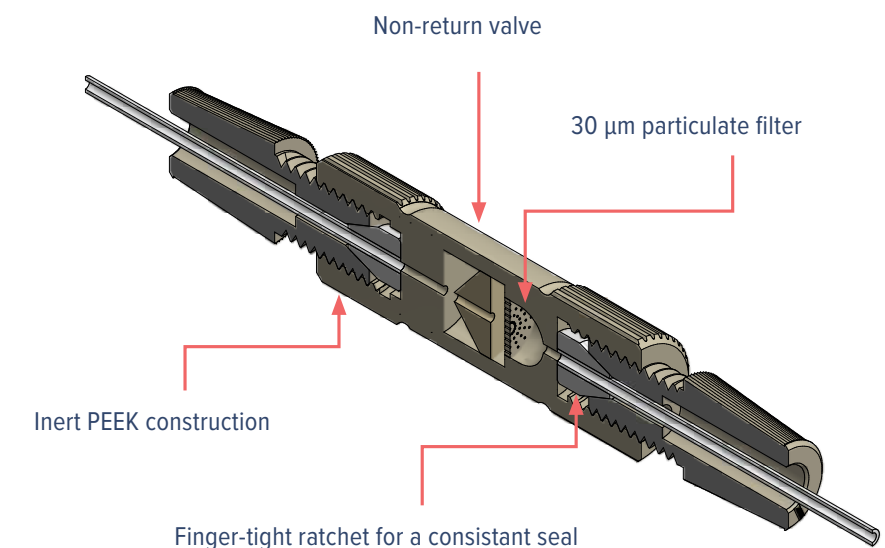
The Guardian DC In-line Non-Return Gas Filter provides protection for your ICP system in two ways:

- A non-return valve prevents acidified sample or rinse solution syphoning into the instrument gas box.
- A unique 30 μm PolyComb filter protects the nebulizer from particulates in the instrument gas supply.

The Guardian DC In-line Non-Return Gas Filter is positioned between the Ar inlet on the Direct Connection nebulizer and the gas supply fitting on the instrument. The In-line Non-Return Gas Filter has a one-way valve that allows argon to flow from the instrument into the nebulizer but prevents liquid siphoning into the instrument. A unique PolyComb 30 μm filter design protects the nebulizer from particulates from the gas supply or from worn or damaged fittings in the gas lines. Unlike Sintered or Frit style filters, the linear honeycomb structure makes PolyComb most resistant to particulate and dissolved solid clogging.

Siphoning of the sample or rinse solution into the nebulizer argon control module on your ICP can occur at the end of an analytical run when the nebulizer gas pressure is turned off and there is liquid in the sample flow path. It is made worse if the autosampler probe stays in the rinse position at the end of a run.

A real problem with using an autosampler for unattended overnight runs, it is a silent, invisible killer of your ICP. An acidified solution in the instrument Ar control module can cause corrosion to electronic sensors in mass flow controllers and damage regulators that can result in expensive repairs to your ICP and un-planned downtime.



- Elegra Argon Humidifier >
- Trident CT Kit >
- Trident In-line Kit for HF >
- Pump Tubing >
- TruFlo Sample Uptake Monitor >
- Guardian In-Line Filters >
- [Guardian Autosampler Probe](#) >
- Sample Introduction Kits >

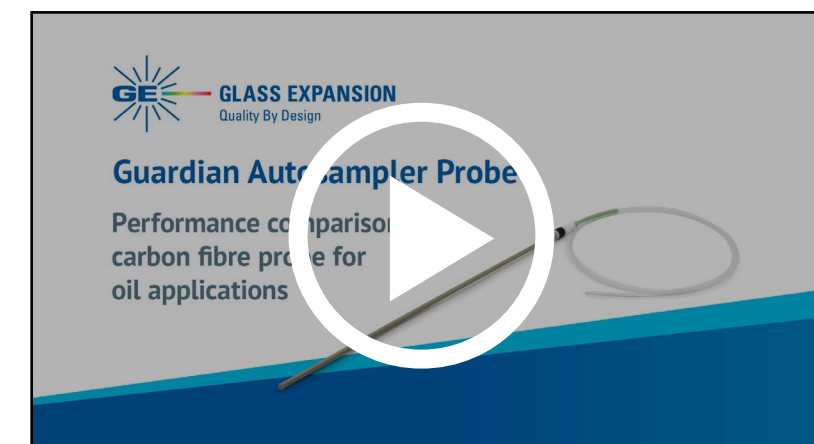
Guardian Autosampler Probe

The unique design of the robust tip—which combines drip-resistance and built-in particle filtering—helps to prevent cross-contamination during probe movement and blockages in your nebulizer and capillary tubing. Constructed entirely from PEEK and PFA, the Guardian autosampler probe also provides exceptional resistance to strong acids and solvents. The Guardian probe has an ID of 1.0mm, with interchangeable UniFit sample capillaries that are available in IDs of 0.3, 0.50, 0.75 and 1.0mm

- Robust tip design eliminates crushed and damaged tips due to misalignment.
- Drip-resistance prevents cross contamination of samples, especially with oils.
- Built-in particle filtering holds back particulates from blocking the line.
- Completely inert design, all PEEK and PTFE construction.
- Interchangeable UniFit™ sample lines available in various IDs (e.g. 0.3, 0.50, 0.75 & 1.0mm)
- Designed to suit Teledyne Cetac, AimLab & Agilent SPS3 /SPS4 Autosamplers.



Guardian Autosampler Probe
Suited for Agilent SPS3 / SPS4 & Aim Lab Autosamplers



Guardian Autosampler Probe Performance Comparison

[Elegra Argon Humidifier](#) >

[Trident CT Kit](#) >

[Trident In-line Kit for HF](#) >

[Pump Tubing](#) >

[TruFlo Sample Uptake Monitor](#) >

[Guardian In-Line Filters](#) >

[Guardian Autosampler Probe](#) >

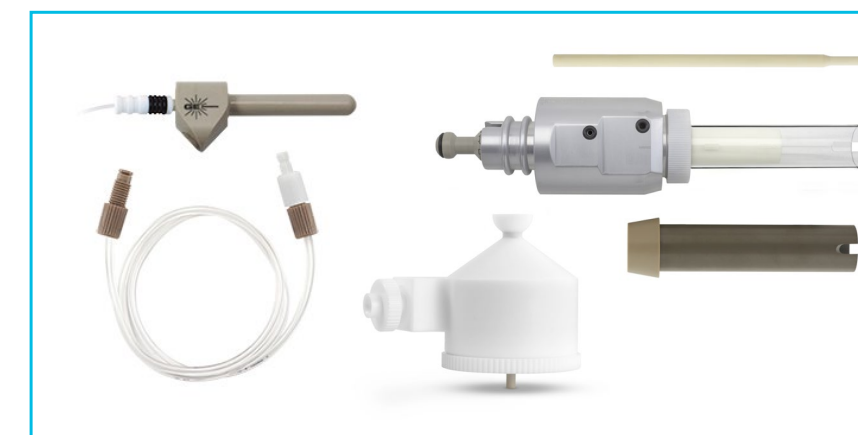
[Sample Introduction Kits](#) >

Sample introduction kits for specific applications

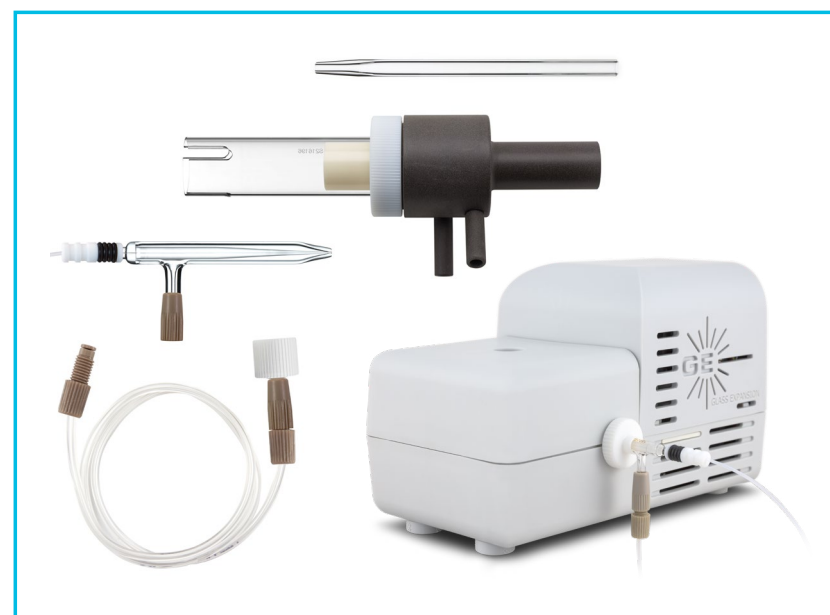
The components of each applications kit have been specially selected to provide optimum performance for the specified application. Even if the complete kit is not needed, the customer can easily identify the best nebulizer, spray chamber and torch for the required application. If we do not already have a kit for the customer's application, the Glass Expansion customer support team can recommend the most appropriate system.

- Standard
- Organics
- Volatile organics
- High solids
- HF resistant

HF Resistant Kit for PerkinElmer® Avio



Standard Kit for PerkinElmer® NexION



High Solids Kit for Thermo Fisher Scientific® PRO Duo



[UniFit drain connector](#)[GazFit connectors](#)[Nebulizer Connectors](#)[Laser Ablation Adaptors](#)[Tubing Connectors & Probes](#)

Spray Chambers

For spray chambers, we provide a UniFit connector for the drain line as part of every spray chamber kit which has a pumped drain. No need for an improvised connection that may be prone to leak.

UniFit drain connector

- Quick-connect
- Integrated capillary
- 1.3mm, 1.6mm and 2.0mm OD sizes

Torches

GazFit connectors are available in a variety of sizes, (4, 5, 6, and 8mm) to connect to the coolant and auxiliary gas lines on torches. This prevents the Tygon tubing from being “welded” to the quartz arms.

GazFit connectors

- High-purity Teflon
- Simple press-fit
- Gas-tight
- No bonding

Fluka RBS-25 Cleaning Solution

Many years of experience have shown us that Fluka RBS-25 is the most effective cleaning solution. Some customers have reported difficulty in obtaining it so we are now supplying it.

- Most effective cleaning solution for nebulizers, spray chambers and torches.
- Better than other detergents or acids



[UniFit drain connector](#) >[GazFit connectors](#) >[Nebulizer Connectors](#) >[Laser Ablation Adaptors](#) >[Tubing Connectors & Probes](#) >

Direct Connection (DC) Nebulizers

Sometimes it is the little things that make a big difference as in the case of easy to use and leak-proof connectors. The graphic shows our U-Series nebulizer sample connection. The Teflon connector fits the outside of the sample inlet port on the nebulizer making an easy installation with zero dead volume. For the nebulizer gas connection, we recommend an argon connector configured to connect directly to the ICP.

U-Series connector

- Eliminates dead volume
- Available with different size capillaries

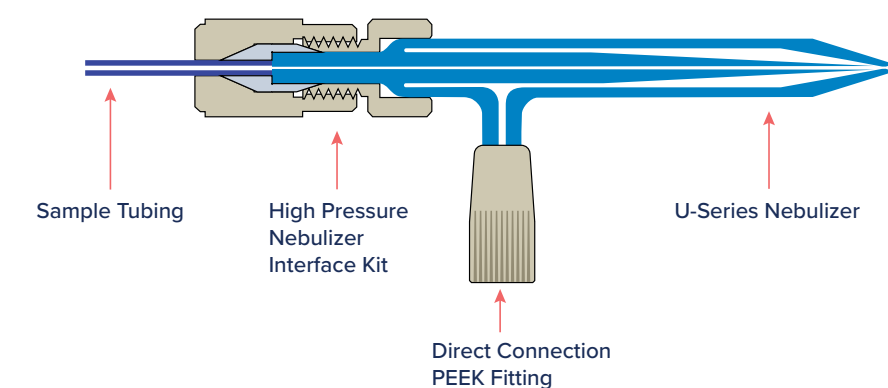
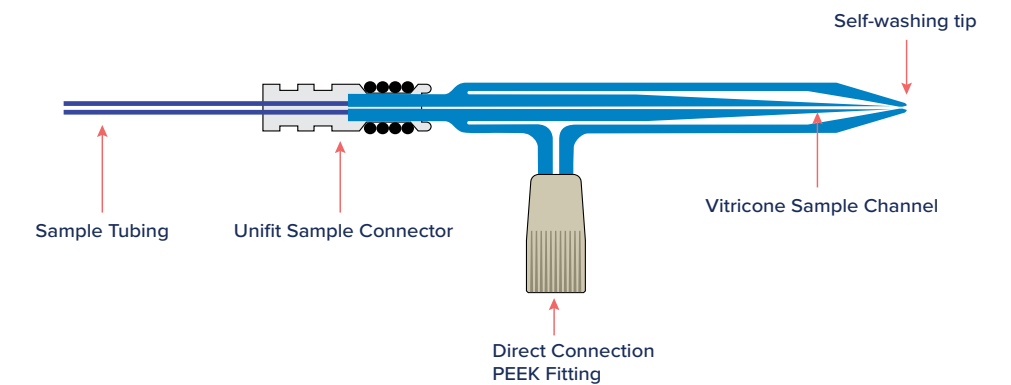
Nebulizer gas connector

- Inert metal free
- Facilitates removal and installation of nebulizer
- Reliable PEEK ratchet fitting ensures leak free gas connection
- Instrument specific Direct Connect flexible argon line

High Pressure Nebulizer Interface Kit

All U-Series nebulizers are compatible with our High Pressure Nebulizer Interface Kit. This easy to install kit provides a quick high integrity connection to the output capillary of an HPLC or LC. When used with either an ICP-OES or ICP-MS, the High Pressure interface facilitates speciation of elemental compounds so that more information about the sample can be garnered.

- Resists blockage
- Fast washout
- Minimal dead volume
- Minimizes peak broadening



[UniFit drain connector](#) >[GazFit connectors](#) >[Nebulizer Connectors](#) >[Laser Ablation Adaptors](#) >[Tubing Connectors & Probes](#) >

Laser Ablation Adaptors

Laser Ablation is a rapidly growing sample introduction system for the introduction of solids into ICP-MS and ICP-OES. The technique is widely used in geochemical, isotopic and environmental analysis, and is also a growing area of research in multi-element imaging of biological materials.

Various adaptor sizes to match each ICP-MS torch



P/N 21-809-4309

The S13 (13mm) ball and Cup connector ([21-809-4309](#)) can be used to provide an input from a laser ablation system and pneumatic nebulization for calibration. This adaptor is used when suitable solid standards are not available.



P/N 70-803-1600

For routine “bulk analysis” Laser Ablation, the cell output can be connected to ICP torch and make up gas added using ([70-803-1600](#)). This mixing chamber allows the ablation cell gas flow to be optimized separately from that of the plasma injector gas flow rate ensuring the best laser ablation performance without compromising plasma performance. It is designed to connect directly to the ICP torch by way of the S13 (13mm) cup and included metal ball joint clip. Also included is P/N [GAZ-06-3.2B](#), design to directly connect soft-walled 1/8 inch ID tubing from the outlet of the Laser to the mixing chamber. (Compatible with the Agilent® 77/78/79/88/8900 ICP-MS)



P/N 31-808-4034

This low volume laser ablation adapter ([31-808-4034](#)) with tangential make-up gas input is used with low dead-volume laser ablation cells to directly connect with the ICP-MS torch to maintain signal intensity and precision and minimizing washout. A zero dead-volume fitting connects a 1/16” OD PEEK capillary transfer tube and an S13 (13mm) cup outlet directly connects to the ICP-MS torch without the need for complex and difficult to use direct injection torches. When used with the Agilent® ICP-MS, this adapter connects directly to the torch whilst keeping all connections outside the torch box. (Compatible with the Agilent® 77/78/79/88/8900 ICP-MS)



P/N 20-809-4550

Laser Ablation Mixing Chamber with S13 (13mm) Ball Joint. Designed for routine Laser Ablation where the cell output to the ICP torch requires a mixing chamber/damper. The mixing chamber is designed to work with Teledyne CETAC Aris.

[UniFit drain connector](#) >[GazFit connectors](#) >[Nebulizer Connectors](#) >[Laser Ablation Adaptors](#) >[Tubing Connectors & Probes](#) >

Laser Ablation Adaptors

Various adaptor sizes to match each ICP-MS torch



P/N 31-808-3863

Connect your rigid 4mm OD/2mm ID laser ablation tubing directly to your Thermo Fisher Scientific® ICP-MS torch using adaptor P/N [31-808-3863](#) in combination with P/N [GAZ-04U](#). (Compatible with Thermo™ Q/RQ/TQ and TOFWEK™ icpTOF)



P/N 21-809-2801

Use [21-809-2801](#) torch adapter to connect any S13 (13mm) cup laser ablation adapter (see page 2 for listing) to your Thermo Fisher Scientific® ICP-MS torch. (Compatible with Thermo® Q/RQ/TQ and TOFWERK™ icpTOF)



P/N 31-808-4289

When an additional gas stream is required to be introduced, use P/N [31-808-4289](#) torch adapter, to connect any S13 (13mm) cup laser ablation adapter to your Thermo Fisher Scientific® ICP-MS torch (Compatible with Thermo® Q/RQ/TQ and TOFWERK™ icpTOF)



P/N 31-808-4107

Use P/N [31-808-4107](#) torch adapter to connect any S13 (13mm) cup laser ablation adapter to your PerkinElmer® ICP-MS torch. (Compatible with PerkinElmer® NexION 1000/2000/5000)



P/N 31-800-1007

Connect to 4mm rigid tubing by a “push-fit” seal. ID: 4mm.



P/N 21-809-4140

Connect to 4mm and 8mm tubing by way of [GAZ-04U](#) and [GAZ-08U](#) or [GAZ-04](#) and [GAZ-08](#). OD: 8mm, ID: 4mm.



P/N 21-809-0965C

Connect to 6mm tubing by way of [GAZ-06U](#) or [GAZ-06](#). OD: 6mm, ID: 4mm.



P/N 31-808-3045

Connect to 4mm tubing by way of [GAZ-04U](#) or [GAZ-04](#). OD: 4mm, ID: 2mm.

[UniFit drain connector](#) >

[GazFit connectors](#) >

[Nebulizer Connectors](#) >

[Laser Ablation Adaptors](#) >

[Tubing Connectors & Probes](#) >

Laser Ablation Adaptors



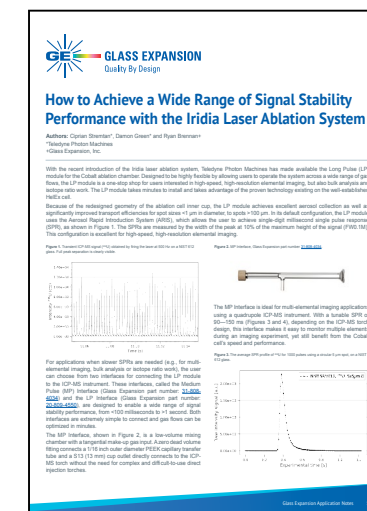
Table 2. Standard GazFit Connectors (for soft walled tubing)

Part Number	Description
GAZ-04	GazFit Connectors for 4mm OD side arm (PKT.4)
GAZ-05	GazFit Connectors for 5mm OD side arm (PKT.4)
GAZ-06	GazFit Connectors for 6mm OD side arm (PKT.4)
GAZ-08	GazFit Connectors for 8mm OD arm (PKT.2)
GAZ-0604	GazFit Connectors, 2 for 6mm OD side arms, 2 for 4mm OD side arms (PKT.4)
GAZ-06-3.2B	GazFit Connectors for 6mm OD side arm with connection for 1/8inch ID tubing (PKT.4)

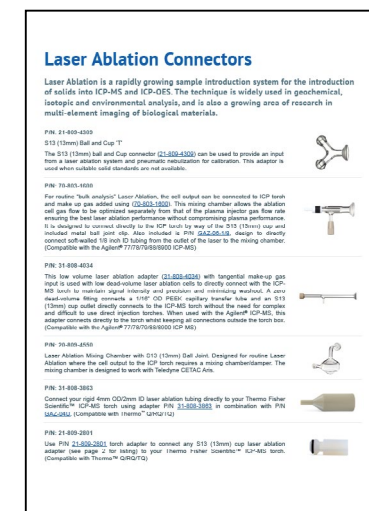


Table 1. GazFit Union Connectors (for rigid walled tubing)

Part Number	Description
GAZ-04U	GazFit Union 4mm (PKT.2)
GAZ-06U	GazFit Union 6mm (PKT.2)
GAZ-08U	GazFit Union 8mm (PKT.2)



Laser Ablation Technical Note



Laser Ablation Flyer

[UniFit drain connector](#) >

[GazFit connectors](#) >

[Nebulizer Connectors](#) >

[Laser Ablation Adaptors](#) >

[Tubing Connectors & Probes](#) >

Reagent Tube with PTFE Sinkers

Another product to make life easier for the analyst is the reagent tube with PTFE sinker. This prevents the end of the sample tube from curling up inside the reagent vessel so that solution is no longer delivered.



Tubing Connector

For 1.3mm tubing order P/N: FT-16-1.3 and for 1.6mm tubing order P/N: FT-16-1.6



Carbon Fibre Autosampler probes

- Encapsulated carbon fibre tube
- Continuous PFA tubing
- Available for most common Autosampler models
- Available in 0.25, 0.50, 0.75 and 1.00 mm ID.



Summary

Introduction

Nebulizers

Spray Chambers

Torches

RF Coils

Cones

Accessories

Fittings & Connectors

Summary

Webinars

Product Search Function

QR Code Information

Customer Comments

Glass Expansion Products



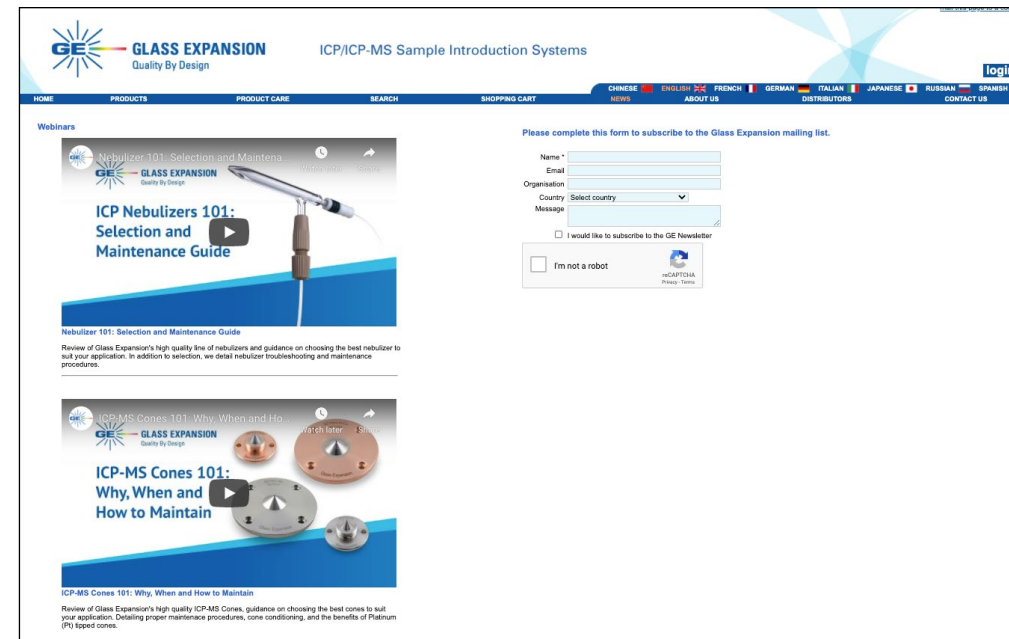
Webinars

The Glass Expansion webinars cover a variety of topics and industries in a series of online video recordings.

Videos Include:

- Review of Glass Expansion's high quality line of products
- Guidance on selecting the best products to suit your application
- Troubleshooting
- Maintenance procedures
- Question and answer segment

To view the recordings, [click here](#) to visit the Glass Expansion Webinar page.



[Return to Contents Page](#)

Webinars >

[Product Search Function](#) >

QR Code Information >

Customer Comments >

Glass Expansion Products >

Product search function on GE website

The Glass Expansion website has a product search function. It shows you the Glass Expansion part number (P/N) by product serial number or OEM part number.



To use this function:

1. When you have an OEM P/N, click and open the last option 'Search for a product by OEM number', then type in your OEM P/N and click submit. This will show the equivalent GE P/N.
2. If you have a serial number of a GE product, click and open the 2nd last option 'Use your product serial number to find its part number', then type in the serial number and click submit. This will show the GE P/N.

The serial number is shown on most GE products as below:



[Return to Contents Page](#)

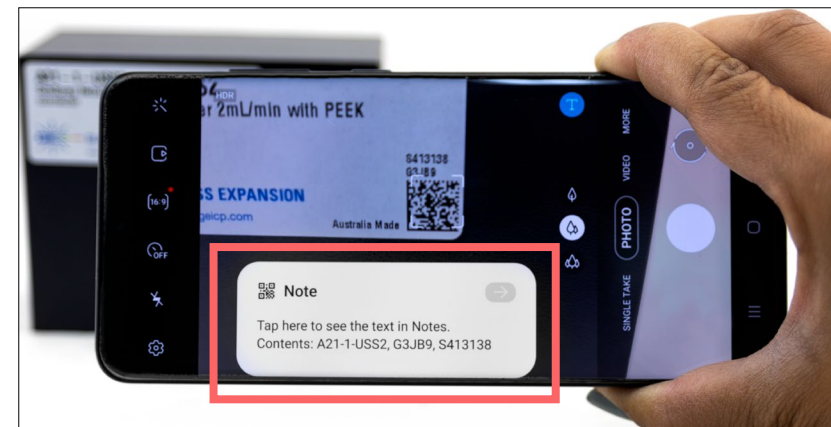
[Webinars](#)[Product Search Function](#)[QR Code Information](#)[Customer Comments](#)[Glass Expansion Products](#)

QR Code Information on packaging

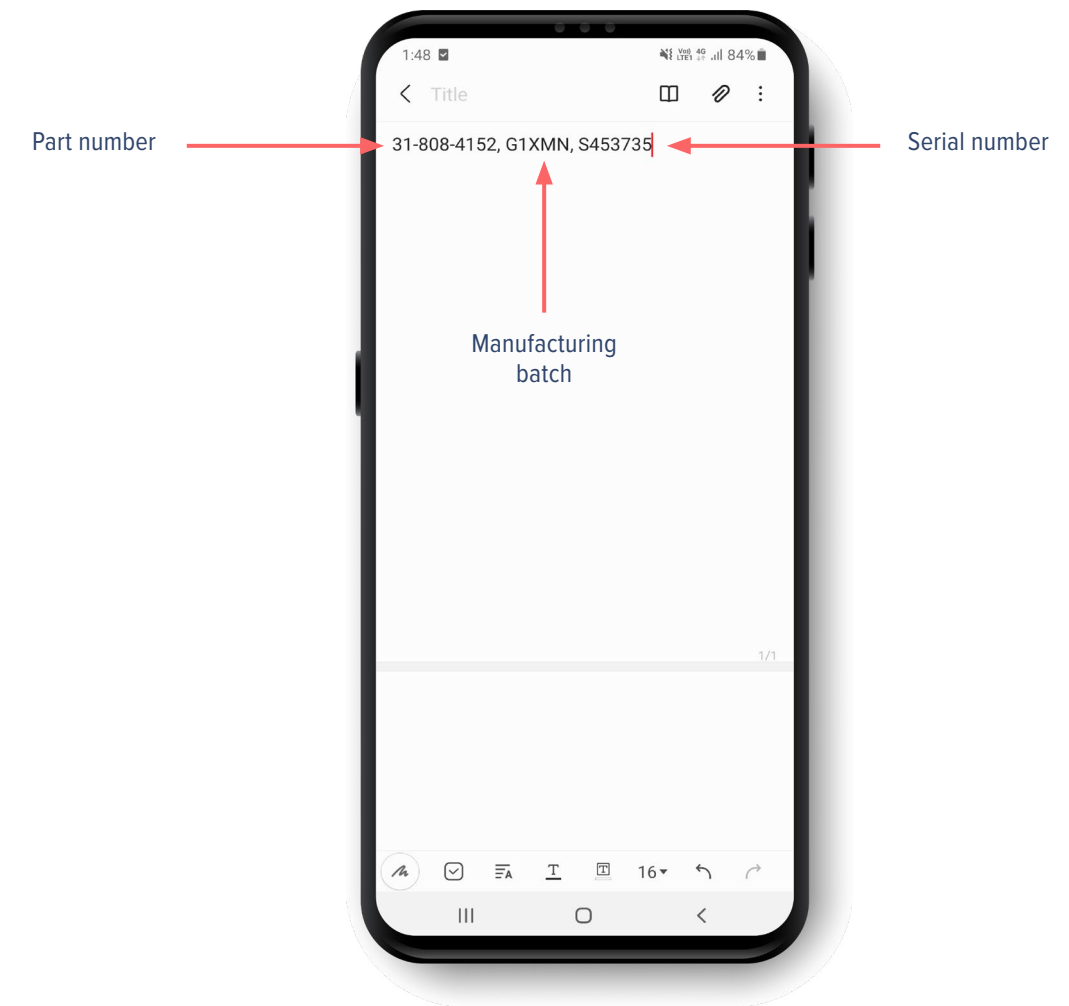
All Glass Expansion products contain a QR code on the label. Once scanned, it contains the part number, manufacturing batch and serial number of the product. Below are instructions on how to view this information on your smart device.



1. The QR Code can be found on the right hand corner of the product label. Point your smartphone camera or a QR code reader to the barcode.



2. Once the smartphone recognises the code, a pop up window will appear. Click this pop up to be taken to your notes where the information will appear.



3. The screen above shows the information contained in the QR code, including the part number, manufacturing batch and serial number of the product. Please note that serial number will not be displayed for all products. Manufacturing batch number can be used for product history in this case.

[Webinars](#)[Product Search Function](#)[QR Code Information](#)[Customer Comments](#)[Glass Expansion Products](#)

Customer comments

We welcome feedback from our customers and we are happy to publish comments in the Customer Comments section of our website. A few examples are shown here:

(In reference to the Elegra) Talking with my operators that are here today neither of them has changed a nebulizer since we put it on.....We had been replacing nebulizers after about a week and half.....I will be ordering 2 more.

Contract laboratory - USA

For our particular application this PCC kit was a great improvement. On specific cases that required four (or more) blank runs to bring the boron level to baseline now we can do it two or one blank run. This allowed us to increase sample throughput by about 50%.

Specialty Chemicals Manufacturer - USA

We like the TruFlo monitor. It has helped us on a number of occasions to track down some minor issues and we use it constantly while running our ICP.

Oil company – USA

The D-Torch is performing very well. The ceramic outer has been in almost constant service 22 hours a day, 6 days a week since we purchased it and we have had no issues ... We are due to purchase a replacement ICP and will certainly be purchasing another D-Torch to go along with it.

Lubricating oils laboratory – Australia

The equipment works extraordinarily well. Keeping temperature at 5degC the noise drops to half as much as without the IsoMist. There is no problem at all with temperature stability and the signal is twice as much as the one obtained without the IsoMist.

University laboratory – Spain

I would like to thank you for an excellent service! The goods were delivered in three(!) working days from the other side of the world. I'm still in a state of disbelief.

Environmental laboratory – Finland

The Ceramic torch is quite excellent, mostly from a maintenance standpoint, it forms much less deposits on it and that which forms is usually very easy to clean ... I do think we'll continue buying ceramic torches mostly because they last much longer and are so much easier to keep clean.

Environmental laboratory – Sweden

We were very pleased with the Eluo – great idea and a lot easier than how we used to clean the nebulisers. Keep up with the great ideas.

Contract laboratory – New Zealand

Summary

[Introduction](#)[Nebulizers](#)[Spray Chambers](#)[Torches](#)[RF Coils](#)[Cones](#)[Accessories](#)[Fittings & Connectors](#)[Summary](#)[Webinars](#) >[Product Search Function](#) >[QR Code Information](#) >[Customer Comments](#) >[Glass Expansion Products](#) >

Glass Expansion Products

Always the Highest Value

To summarize, Glass Expansion has gone to great lengths to consider all aspects of the ICP spectrometer laboratory and to offer the quality products and support that help you to achieve high-quality analytical results.

- Tightest tolerances
- Most innovative designs
- Most reproducible
- Guaranteed superior performance
- Backed up with technical support
- Designed to facilitate lab work

[< Return to Contents Page](#)



Asia Pacific

Glass Expansion
6 Central Boulevard
Port Melbourne, Vic 3207,
Australia
Telephone: +61 3 9320 1111
Email: enquiries@geicp.com



Americas

Glass Expansion
31 Jonathan Bourne Drive, Unit 7,
Pocasset, MA 02559,
USA
Toll Free Phone: 800 208 0097
Telephone: 508 563 1800
Facsimile: 508 563 1802
Email: geusa@geicp.com



Europe

Glass Expansion
Friedenbachstrasse 9,
35781 Weilburg,
Germany
Telephone: +49 6471 3778517
Email: gegmbh@geicp.com

